

ZONING RESOLUTION
JERUSALEM TOWNSHIP
LUCAS COUNTY, OHIO

BOARD OF TRUSTEES

David Bench, Chairman
Beau Miller, Vice Chairman
Mark Sattler

TOWNSHIP FISCAL OFFICER

Joel Moszkowicz

ZONING COMMISSION

Brad LaRue, Chairman
Tim Titgemeyer, Vice Chair
Jennifer Shepherd
Frank Ulrich
James Boothby, Alternate

ZONING BOARD OF APPEALS

Richard Carstensen, Chairman
Butch Berger
Barbara Gall
Sandra Pegler
Jim Barron
Jason Box, Alternate

ZONING INSPECTOR

Linda Rossler

TEXT AMENDMENTS

<u>CASE</u>	<u>SUBJECT</u>	<u>TRUSTEE ACTION</u>
Z28-C48	Marina and Yacht Clubs	06-09-80
Z28-C61	Various Sections of Resolution	08-13-84
Z28-C62	Group Homes	06-01-85
Z28-C76	Signs	08-17-87
Z28-C77	Dish Antennas	08-17-87
Z28-C78	Two-Family Dwellings	08-17-87
Z28-C79	Marina	08-17-87
Z28-C83	Fireworks	01-04-88
Z28-C104	Commercial Fishing	07-08-92
Z28-C113	Sign Setbacks	01-11-95
Z28-C117	Various Sections of Resolution	10-09-96
Z28-C122	Manufactured Home and Adult Amusement	02-29-00
Z28-C123	Adult Entertainment Facilities	01-08-02
Z28-C124	Building Setbacks and Minimum House Size	01-09-01
Z28-C129	Definition of Vessel and Telecommunication Tower	05-22-01
Z28-C130	State Route 2 Overlay District	
Z28-C134	Projections and Wind Turbines	04-08-08
Z28-C142	Medical Marijuana Facilities	12-20-17
Z28-C143	Maintaining Livestock and Blighting Factors	12-20-17
Z28-C145	Riparian Setbacks	10-13-20

TABLE OF CONTENTS

		<u>PAGE</u>
SECTION 1	GENERAL PROVISIONS	1 - 1
Section 100	Enactment; Title	1 - 1
Section 101	Purpose	1 - 1
Section 102	Interpretation and Relationship to Other Regulations	1 - 1
Section 103	Severability	1 - 1
Section 104	Repeal of Conflicting Resolutions	1 - 1
Section 105	Effective Date	1 - 1
Section 106	Area of Jurisdiction	1 - 1
SECTION 2	APPLICABILITY	2 - 1
Section 200	General Applicability of Zoning Resolution	2 - 1
Section 201	Agriculture	2 - 1
Section 202	Public Utilities	2 - 3
Section 203	Exceptions	2 - 3
SECTION 3	PROVISIONS FOR OFFICIAL ZONING MAP	3 - 1
Section 300	Official Zoning Map	3 - 1
Section 301	Interpretation of District Boundaries	3 - 1
Section 302	Establishment of Districts	3 - 2
SECTION 4	PUBLIC/OPEN SPACE DISTRICT	4 - 1
Section 400	Purpose	4 - 1
Section 401	Permitted Uses	4 - 1
Section 402	Special Uses	4 - 1
Section 403	Development Standards	4 - 1
SECTION 5	AGRICULTURE DISTRICT	5 - 1
Section 500	Purpose	5 - 1
Section 501	Permitted Uses	5 - 1
Section 502	Special Uses	5 - 1
Section 503	Development Standards	5 - 1
SECTION 6	RESIDENTIAL DISTRICT	6 - 1
Section 600	Purpose	6 - 1
Section 601	Permitted Uses	6 - 1
Section 602	Special Uses	6 - 1
Section 603	Development Standards	6 - 1

		<u>PAGE</u>
SECTION 7	R-3 MULTI-FAMILY RESIDENTIAL DISTRICT	7 - 1
Section 700	Purpose	7 - 1
Section 701	Permitted Uses	7 - 1
Section 702	Special Uses	7 - 1
Section 703	Development Standards	7 - 1
SECTION 8	MHP MANUFACTURED HOME PARK DISTRICT	8 - 1
Section 800	Purpose	8 - 1
Section 801	Permitted Uses	8 - 1
Section 802	Special Uses	8 - 1
Section 803	Approval Procedure	8 - 1
SECTION 9	C-1 NEIGHBORHOOD COMMERCIAL DISTRICT	9 - 1
Section 900	Purpose	9 - 1
Section 901	Permitted Uses	9 - 1
Section 902	Special Uses	9 - 1
Section 903	Development Standards	9 - 1
SECTION 10	C-2 GENERAL COMMERCIAL DISTRICT	10 - 1
Section 1000	Purpose	10 - 1
Section 1001	Permitted Uses	10 - 1
Section 1002	Development Standards	10 - 1
SECTION 11	R-C RECREATIONAL/COMMERCIAL DISTRICT	11 - 1
Section 1100	Purpose	11 - 1
Section 1101	Permitted Uses	11 - 1
Section 1102	Special Uses	11 - 1
Section 1103	Development Standards	11 - 1
SECTION 12	M-1 INDUSTRIAL DISTRICT	12 - 1
Section 1200	Purpose	12 - 1
Section 1201	Permitted Uses	12 - 1
Section 1202	Special Uses	12 - 2
Section 1203	Development Standards	12 - 2
SECTION 13	PLANNED UNIT DEVELOPMENT	13 - 1
Section 1300	Purpose	13 - 1
Section 1301	Description	13 - 1
Section 1302	Procedure	13 - 1
Section 1303	Additional Information	13 - 2
Section 1304	Standards	13 - 2
Section 1305	Changes to Approved Plan	13 - 4
Section 1306	Expiration and Extension of Approval Period	13 - 5

		<u>PAGE</u>
SECTION 14	STATE ROUTE 2 OVERLAY DISTRICT	14 - 1
Section 1400	Purpose and Intent	14 - 1
Section 1401	State Route 2 Overlay District Boundaries	14 - 1
Section 1402	Review and Approval Procedures	14 - 1
Section 1403	Permitted and Special Uses	14 - 1
Section 1404	Excluded Uses	14 - 1
Section 1405	Accessory Buildings and Uses	14 - 2
Section 1406	Development Standards	14 - 2
Section 1407	Access to Individual Parcels	14 - 2
Section 1408	Access Permits	14 - 3
Section 1409	Access Options	14 - 3
Section 1410	Traffic Impact Study	14 - 3
Section 1411	Traffic Assessment Study	14 - 3
Section 1412	Architectural Review Requirements	14 - 4
Section 1413	Landscape Review Requirements	14 - 4
SECTION 15	RIPARIAN SETBACK REGULATIONS <small>(REV. 10-13-20, Z28-C145)</small>	15 – 1
Section 1500	Purpose	15 - 1
Section 1501	Riparian Setbacks	15 - 1
Section 1502	Permitted Uses	15 - 1
Section 1503	Wetland within Riparian Setback Areas	15 - 2
Section 1504	Permitted Uses with prior approval	15 - 2
Section 1505	Prohibited Uses	15 - 3
Section 1506	Sewage Disposal or Treatment Areas	15 - 4
Section 1507	Non-conforming Structures or Uses	15 - 4
Section 1508	Boundary Interpretation and Appeals Procedure	15 - 5
Section 1509	Variances	15 - 5
Section 1510	Inspection of Riparian Setback	15 - 6
Section 1511	Applicability, Compliance and Violations	15 - 6
SECTION 16	SUPPLEMENTARY REGULATIONS	16 - 1
Section 1600	General	16 - 1
Section 1601	Accessory Building or Structure	16 - 1
Section 1602	Architectural Projections	16 - 1
Section 1603	Fences	16 - 2
Section 1604	Mineral Extraction, Storage, Processing, & Manufacture	16 - 2
Section 1605	More Than One Principal Building	16 - 5
Section 1606	Noise	16 - 5
Section 1607	Ponds	16 - 5
Section 1608	Causes of Blight or Blighting Factors	16 - 7
Section 1609	Satellite Dish Antennas	16 - 8
Section 1610	Commercial Fishing Operations	16 - 9
Section 1611	Building and Grading Completion	16 - 9
Section 1612	Sexually Oriented Business	16 - 9
Section 1613	Telecommunication Towers	16 - 10
Section 1614	Supplemental Yard Regulations	16 - 11

		<u>PAGE</u>
SECTION 16	SUPPLEMENTARY REGULATIONS (cont'd)	16 - 1
Section 1615	Water Front Lots	16 - 12
Section 1616	Major Roadway Setback Requirements	16 - 12
Section 1617	Swimming Pools	16 - 12
Section 1618	Temporary Buildings and Uses	16 - 13
Section 1619	Yard/Garage Sale	16 - 14
Section 1620	Motor Vehicle Salvage Yards	16 - 14
Section 1621	Treatment of Sewage	16 - 15
Section 1622	Private Tennis Courts	16 - 16
Section 1623	Self Storage Facilities	16 - 16
Section 1624	Home Occupations	16 - 17
Section 1625	Filling of Land	16 - 18
Section 1626	Outdoor Parking and Storage of Vehicles, Watercraft & Trailers	16 - 18
Section 1627	Lawn/Tree Service	16 - 19
Section 1628	Storage Yard	16 - 19
Section 1629	Small Wind Turbines	
Section 1630	Medical Marijuana Facilities	
SECTION 17	NON-CONFORMITIES	17- 1
Section 1700	Purpose	17- 1
Section 1701	Non-Conforming Lots of Record	17- 1
Section 1702	Non-Conforming Use of Land	17- 1
Section 1703	Non-Conforming Buildings and Structures	17- 2
Section 1704	Prior Zoning Approvals	17- 2
Section 1705	Repairs and Maintenance	17- 2
SECTION 18	SIGNS AND OUTDOOR ADVERTISING	18- 1
Section 1800	Purpose	18- 1
Section 1801	Definitions	18- 1
Section 1802	General Provisions	18- 3
Section 1803	Prohibited Signs	18- 4
Section 1804	Exemptions	18- 5
Section 1805	Agricultural, Residential, and Open Space Districts	18- 5
Section 1806	Commercial and Industrial Districts	18- 6
Section 1807	Common Signage Plans for Multiple Uses	18- 7
Section 1808	Off-Premise Signs	18- 8
SECTION 19	SITE PLAN REVIEW	19- 1
Section 1900	Purpose	19- 1
Section 1901	Application	19- 1
Section 1902	Requirements	19- 1
Section 1903	Approval Procedure	19 - 3
Section 1904	Expiration & Extension of Site Plan Approval	19 - 3

		<u>PAGE</u>
SECTION 20	LANDSCAPING REQUIREMENTS	20 - 1
Section 2000	Purpose	20 - 1
Section 2001	Requirements	20 - 1
Section 2002	Plant Material Specifications	20 - 3
Section 2003	Maintenance and Replacement Requirements	20 - 4
SECTION 21	PARKING REQUIREMENTS	21 - 1
Section 2100	General Parking Requirements	21 - 1
Section 2101	Off-Street Parking Design Standards	21 - 1
Section 2102	Determination of Required Spaces	21 - 4
Section 2103	Parking Space Requirements	21 - 4
Section 2104	Off-Street Areas with Drive-Up/Drive-Thru Service	21 - 6
Section 2105	Parking of Disabled Vehicles and Watercraft	21 - 7
Section 2106	Parking and Storage of Recreation Vehicles and Watercraft	21 - 7
SECTION 22	PROCEDURES AND REQUIREMENTS FOR SPECIAL USES	22 - 1
Section 2200	Purpose	22 - 1
Section 2201	Standards	22 - 1
Section 2202	Procedure	22 - 1
Section 2203	Conditions of Approval	22 - 1
Section 2204	Expiration or Revocation of Special Use	22 - 1
SECTION 23	ZONING CHANGES AND TEXT AMENDMENTS	23 - 1
Section 2300	Authority	23 - 1
Section 2301	Procedures	23 - 1
Section 2302	Application and Fees	23 - 1
Section 2303	Transmittal to the Lucas County Plan Commission	23 - 1
Section 2304	Hearing and Notice by Zoning Commission	23 - 1
Section 2305	Recommendation by Zoning Commission	23 - 2
Section 2306	Public Hearing and Notice by Board of Township Trustees	23 - 2
Section 2307	Action by Board of Township Trustees	23 - 2
Section 2308	Effective Date and Referendum	23 - 3
SECTION 24	ENFORCEMENT	24 - 1
Section 2400	Zoning Inspector	24 - 1
Section 2401	Zoning Certificate Required	24 - 1
Section 2402	Approval of Zoning Certificate	24 - 1
Section 2403	Enforcement and Penalties	24 - 2
Section 2404	Schedule of Fees, Charges, and Expenses	24 - 2
SECTION 25	ZONING COMMISSION	25 - 1
Section 2500	Jerusalem Township Zoning Commission	25 - 1
Section 2501	Organization	25 - 1
Section 2502	Meetings	25 - 1

Section 2503	Duties of the Zoning Commission	25 - 1
		<u>PAGE</u>
SECTION 26	BOARD OF ZONING APPEALS	26 - 1
Section 2600	Jerusalem Township Board of Zoning Appeals	26 - 1
Section 2601	Meetings	26 - 1
Section 2602	Duties of the Board of Zoning Appeals	26 - 1
Section 2603	Appeal Requirements	26 - 1
Section 2604	Requirements for a Variance Request and Approval	26 - 2
Section 2605	Conditions of Approval	26 - 2
Section 2606	Applications	26 - 3
Section 2607	Public Hearing and Notice	26 - 3
SECTION 27	DEFINITIONS	27 - 1

SECTION 1

GENERAL PROVISIONS

100 ENACTMENT; TITLE

The Board of Township Trustees in accordance with the enabling legislation for Township zoning as provided in ORC 519 hereby provides as follows: This Resolution shall be known as and may be cited to as the "Zoning Resolution of Jerusalem Township, as amended, and is referred to herein as "Resolution".

101 PURPOSE

The purpose of this Resolution is to promote the public health, safety, and general welfare of the residents of Jerusalem Township. This Resolution shall serve the general good of the community as a whole, protect property value, and secure the most appropriate use of the land, in accordance with the adopted Jerusalem Township Land Use Plan, 2001 (and as amended). This resolution is adopted for the purpose of protecting and promoting public health, safety, morals, comfort, and general welfare; conserving and protecting property and facilitating adequate but economical provision of public improvements; and amending the Zoning Resolution of the Board of Trustees of Jerusalem Township, Lucas County, Ohio, effective May 1960, as amended to the date of the adoption of this amending resolution, in each and every part thereof that is inconsistent with this amending resolution.

102 INTERPRETATION AND RELATIONSHIP TO OTHER REGULATIONS

The interpretation and application of any provisions of this Resolution shall be held to be the minimum requirements, adopted for the promotion of the public health, safety, and general welfare. When the requirements of this Resolution conflict with the requirements of any other lawfully adopted rules, regulation, or resolutions, the most restrictive requirements imposing the higher standards, shall apply.

103 SEVERABILITY

Should this Resolution, or any section of this Resolution, be declared by a court to be unconstitutional or invalid, such a decision shall not affect the validity of this Resolution as a whole, or any other parts thereof, other than the part declared unconstitutional or invalid; in the event of such a declaration, then the applicable provision of the prior Zoning Resolution (Zoning Resolution, May 1960, as amended) is hereby re-instated.

104 REPEAL OF CONFLICTING RESOLUTIONS

All resolutions in conflict with this Resolution, or inconsistent with the provisions of the Resolution, are hereby repealed to the extent necessary to give this Resolution full force and effect.

105 EFFECTIVE DATE

This Resolution shall become effective from and after the date of its approval and adoption by the Board of Township Trustees, as provided in ORC 519.12.

106 AREA OF JURISDICTION

The provisions of this Resolution apply to all unincorporated areas of Jerusalem Township, Lucas County, Ohio.

SECTION 2

APPLICABILITY

200 GENERAL APPLICABILITY OF ZONING RESOLUTION

No structure, or part thereof shall be placed upon or moved onto land, constructed, reconstructed, enlarged, or structurally altered, nor shall any building or land be used or occupied in a manner which does not comply with the district regulations established by this Resolution for the district in which the building, structure, and/or land is located.

200.01 Lot Size Requirements and the Subdivision of Land

No lot or lot of land held under one (1) ownership, with or without a building, at the time this Resolution became effective, shall be reduced, or subdivided in any manner except in conformance with the minimum lot width and lot area required by this Resolution.

200.02 Reductions in Yard Requirements

No building and/or structure shall be enlarged which would result in decreasing a yard below the minimum requirements of the applicable zoning district.

200.03 Location of Uses on a Single Lot

Unless otherwise specifically allowed in Section 1505 – Supplemental Regulations, every principal building whether presently existing or hereafter constructed, relocated or structurally altered shall be located on a single lot.

200.04 Unsafe Buildings

Nothing in this Resolution shall prevent the strengthening, or restoring to a safe condition, any structure, or part thereof declared unsafe by a proper authority.

200.05 Conversion of Dwellings

The conversion of any structure into a dwelling or the conversion of any dwelling to accommodate an increased number of dwelling units or families, is permitted only in accordance with all requirements of this Resolution.

200.06 Parking Requirements

No land use shall change from one use to another use, without first meeting the parking requirements for the new use.

201 AGRICULTURE

Pursuant to the ORC, the use of land for agricultural purposes or the construction or use of buildings or structures incidental to the use for agricultural purposes of the land on which such buildings or structures are located, shall be permitted in all districts established by this Resolution. No zoning certificate shall be required for any such **agricultural** building or structure, except where regulated within platted areas on lots of less than five (5) acres **and for** farm markets.

201.01 Dwellings in an Agriculture District

Dwellings on the same property as agricultural operations are not herein defined as agricultural structures and are subject to all requirements contained in this Resolution.

201.02 Raising/Maintaining livestock (Farm Animals)

In a platted subdivision approved under the ORC 711.05, 711.09 or 711.10, or in any area consisting of fifteen or more lots approved under the ORC 711.131 that are contiguous to one another, or some of which are contiguous to one another and adjacent to one side of a dedicated public road, and the balance of which are contiguous to one another and adjacent to the opposite side of the same dedicated public road, the following regulations shall apply:

1. On lots of **three (3)** acres or less, the breeding, raising or maintaining of farm animals such as horses, pigs, cows, sheep, goats, fowl, and similar livestock is prohibited. (Rev. 12-20-17, Z28-C143)
2. On lots greater than **three (3)** acres but not greater than five (5) acres, a lot owner may stable or keep livestock provided buildings or stables incident to the housing of livestock shall not be permitted within fifty (50') feet of a dwelling or an adjacent property line;
3. No farm animals shall be pastured within five (5') feet on any lot line;
4. Keeping of chickens - No person shall keep chickens unless the following conditions are met.
 - A. **Lot size** - On lots of one (1) acre or more
 - B. **Enclosure** - Hens shall be provided with a covered, predator-proof coop or cage that is well-ventilated and designed to be easily accessed for cleaning. The coop shall allow at least one square foot per hen. Hens shall have access to an outdoor enclosure that is adequately fenced to contain the birds on the property.
 - C. **Sanitation** - The coop and outdoor enclosure must be kept in a sanitary condition and free from offensive odors. The coop and outdoor enclosure must be cleaned on a regular basis to prevent accumulation of waste.
 - D. **Roosters** - It is unlawful for any person to keep roosters.

(Rev. 12-20-17, Z28-C143)

5. There shall be at least one (1) acre per horse or pony on a single property on which the horses or ponies are stabled.

No owner of any lot in a platted subdivision shall permit the use of any lot for the keeping of farm animals or livestock that produces, directly or indirectly, the noxious odor of the animals and livestock, insects, flies or other carriers of waste material, including, but not limited to, the transmission or flow of animal waste through the ground or by air from the lot to any adjoining lot or public right-of-way, or any other result of an animal or an animal husbandry ownership or use, which endangers the public's health, safety and general welfare on the lot or the owners or occupier of any adjoining lot, and the Board of Township Trustees may determine and find any such use to be a nuisance and that such nuisance causes injury to the property of another, endangers life and health, is offensive to the senses, violates laws of decency, or obstructs the reasonable and comfortable use of one's property.

201.03 Farm Market

Farm markets are allowed in any zoning district if fifty (50%) percent or more of the gross income received from the farm market is derived from produce raised on farms owned or operated by the market operator in a normal crop year. Farm markets that do not provide more than fifty (50%) percent of the gross income from produce raised on land owned or operated by the market operator is a Special Use in all zoning districts and subject to Section 22 – Procedures and Requirements for Special Uses, and the other provisions of Section 201 – Agriculture. All farm markets are subject to Section 19 – Site Plan Review.

202 PUBLIC UTILITIES

Pursuant to ORC 519.21, this Resolution does not regulate the location, construction, reconstruction, removal, use or enlargement of any buildings or structure or any public utility or railroad, whether publicly or privately owned, or the use of land by any public utility or railroad, for the operation of its business. This Resolution shall require that site plans be submitted to the Zoning Commission and be reviewed in accordance with Section 19 – Site Plan Review. **See Section 1613 for the regulations of Telecommunication Towers.**

203 EXCEPTIONS (Variances)

Exceptions to these regulations in specific cases in accordance with ORC 519.14 may be authorized by the Board of Zoning Appeals where there are practical difficulties or unnecessary hardships in carrying out the strict letter of this Resolution providing such exception is in harmony with the general purpose and intent of the Resolution and in accordance with the procedures and provisions specified in Section 26. Hardship shall be based on physical limitations of the land or structures and does not encompass financial considerations.

SECTION 3

PROVISIONS FOR OFFICIAL ZONING MAP

300 OFFICIAL ZONING MAP

The location and boundaries of zoning districts are shown on the map titled "The Official Jerusalem Township Zoning Map" herein. A certified copy of this map is on file at the Jerusalem Township Hall and is hereby declared to be a part of this Resolution.

301 INTERPRETATION OF DISTRICT BOUNDARIES

Where uncertainty exists with respect to the boundaries of the zoning district as shown on the Zoning Map, the following rules shall apply:

301.01 Parallel District Boundaries

Where district boundaries appear to be approximately parallel to the center lines or street lines of the streets, or the center lines or right-of-way lines of highways, such district boundaries shall be construed as parallel thereto and at such distance therefrom as indicated on the official Zoning Map. If no distance is given, such dimensions shall be determined by the use of the scale shown on the Official Zoning Map.

301.02 Lot Lines, Railroad Lines, and Waterways

Where district boundaries approximately follow lot lines such lot lines shall be construed as a boundary of a zoning district. Where the boundary of a district follows a railroad line, such boundary shall be deemed to be located in the middle of the main tracks of said railroad line. Where the boundary of a district follows (or is parallel to) a waterway, such boundary shall be deemed to be located in the middle of the waterway.

301.03 Interpretation by Zoning Board of Appeals

Any questions of interpretation of the Official Zoning Map, which cannot otherwise be resolved, shall be referred to the Zoning Board of Appeals for determination, in accordance with Section 26 – Zoning Board of Appeals.

ESTABLISHMENT OF DISTRICTS

For the purpose of regulating and restricting the location of buildings, structures and land use, Jerusalem Township is divided into zoning districts as shown on the Official Zoning Map. These districts include the following, and may be illustrated on the Official Zoning Map.

ZONING DISTRICTS

OS/P	Open Space/Park District
A/R	Agricultural/Rural Residential
R-1	Single Family Residential
R-3	Multi-Family Residential
MHP	Mobile Home Park
C-1	Neighborhood Commercial
C-2	General Commercial
R-C	Recreational Commercial
M-1	General Industrial

SECTION 4

OS/P OPEN SPACE/PARK DISTRICT

400 PURPOSE

The purpose of the Open Space/Park (OS/P) District is to preserve and protect significant natural areas, park and recreation areas, drainage ways and floodplains, and to provide for the public land use of Jerusalem Township.

401 PERMITTED USES

The following uses are permitted in the Open Space/Park (OS/P) District:

- Accessory uses and structures
- Cemetery (public/private)
- Community pool (See Supplemental Regulations – Section 1617.02)
- Conservation areas
- Public uses
- Public parks

402 SPECIAL USES

The following use may be approved in accordance with Section 22 – Procedures & Requirements for Special Uses:

- Golf course
- Telecommunication tower (See Supplemental Regulations – Section 1613)

403 DEVELOPMENT STANDARDS

All buildings, structures, lots, and land uses within the Open Space/Park (OS/P) District must meet the requirements of Section 16 – Supplemental Regulations, and the following standards:

403.01 Height Limits

No structure shall be constructed or enlarged to exceed thirty-five (35') feet in height.

403.02 Area Requirements

All lots shall meet the following area, coverage, and yard requirements:

- Lot Area:** There is no minimum lot area.
- Front Yard:** Thirty-five (35') feet (See Supplemental Regulations – Section 1615 and Section 1616)
- Side Yard:** Ten percent (10%) of the lot width or ten (10') feet, whichever is less.
- Rear Yard:** Thirty-five (35') feet

SECTION 5

A/R AGRICULTURE/RURAL RESIDENTIAL DISTRICT

500 PURPOSE

The A/R Agriculture/Rural Residential Zoning District is established for areas that consist of large parcels of commercially cultivated land, farms and single-family dwellings. To maintain the rural areas of Jerusalem Township, this District is established for low density single-family dwellings on lots two (2) acres in size or larger.

501 PERMITTED USES

The following uses are permitted in the Agriculture/Rural Residential (A/R) District:

Accessory uses and structures (See Supplemental Regulations Section 1601)	Commercial grain elevator/storage
Agriculture	Dwelling, single-family
Boarding and stabling of horses (private)	Home occupation
Commercial fishing operations (See Supplemental Regulations Section 1610)	Oil and gas drilling/wells
	Permanently sited manufactured home
	Public Uses
	Small Wind Turbine (see Supplemental Regulations – Section 1629)

502 SPECIAL USES

The following uses may be approved pursuant to Section 22 – Procedures & Requirements for Special Uses:

Airport or aircraft landing field	Kennel
Assisted living facility	Lawn care service
Boarding and stabling of horses (commercial)	Nursery/greenhouse
Church or place of worship	Oil and gas drilling/wells
Community pool (See Supplemental Regulations – Section 1617.02)	Cemetery
Golf course	Private schools
	Radio or television station or transmitter
	Recreational facility, outdoor
	Telecommunication tower (See Supplemental Regulations – Section 1613)

503 DEVELOPMENT STANDARDS

All buildings, structures, lots, and land uses within the Agriculture/Rural (A/R) District must meet the requirements of Section 16 – Supplemental Regulations and the following standards:

503.01 Height Limits

No structure, except those for agricultural purposes, shall be constructed or enlarged to exceed forty-five (45') feet in height.

503.02 Area Requirements

All lots shall meet the following minimum requirements:

Lot Area: One and one half (1 ½) acres

Lot Width: One hundred fifty (150') feet.

Front Yard: Thirty-five (35') feet (See Supplemental Regulations – Section 1615 and Section 1616)

Side Yard: Fifteen (15') feet

Rear Yard: Thirty-five (35') feet

503.03 Minimum floor area requirement for all dwellings:

One thousand two hundred (1,200) sq. ft.

503.04 Minimum width and depth for all dwellings:

Twenty-two (22') feet

SECTION 6

R-1 SINGLE FAMILY RESIDENTIAL DISTRICT

600 PURPOSE

The purpose of the Single Family Residential (R-1) District is to provide areas for single family dwellings that are serviced with public water lines and sanitary sewers.

601 PERMITTED USES

The following uses are permitted in the Residential (R-1) District:

Accessory uses and accessory structures	Home occupation
Agriculture	Permanently sited manufactured home
Dwelling, single-family	

602 SPECIAL USES

The following uses may be approved pursuant to Section 22 – Procedures & Requirements for Special Uses:

Church or place of worship
Community pool (See Supplemental Regulations – Section 1617.02)
Telecommunication tower (See Supplemental Regulations – Section 1613)

603 DEVELOPMENT STANDARDS

All buildings, structures, lots, and land uses within the Residential (R-1) District must meet the requirements of Section 16 – Supplemental Regulations, and the following development standards:

603.01 Height Limits

No structure, shall be erected or enlarged to exceed forty-five (45') feet in height.

603.02 Area Requirements

All lots shall have the following minimum requirements:

Lot Area: 12,000 sq. ft.
Lot Width: Seventy-five (75') feet
Front Yard: Thirty-five (35') feet (See Supplemental Regulations – Section 1615 and Section 1616)
Side Yard: Fifteen (15') feet
Rear Yard: Thirty-five (35') feet

603.03 Minimum floor Area for all Dwellings:

1200 sq. ft. for a single-story dwelling

603.04 Minimum Width and Depth for all Dwellings:

Twenty-two (22') feet

SECTION 7

R-3 MULTI-FAMILY RESIDENTIAL DISTRICT

700 PURPOSE

The purpose of the Multi-family Residential (R-3) District is to provide areas for multiple family dwellings in an area that is serviced with public water lines and sanitary sewers.

701 PERMITTED USES

The following uses are permitted in the R-3 Zoning District:

Accessory uses and accessory structures	Dwelling, two-family
Assisted living facility	Home occupation
Dwelling, multi-family	Nursing home
Dwelling, single-family	Permanently sited manufactured home

702 SPECIAL USES

The following uses may be approved pursuant to Section 22 – Procedures & Requirements for Special Uses:

Day care facility	Self-service storage facilities (See Supplemental Regulations – Section 1623)
Church or place of worship	Telecommunications tower (See Supplemental Regulations – Section 1613)
Recreation facility, outdoor or indoor	

703 DEVELOPMENT STANDARDS

All buildings, structures, lots, and land uses within the Multi-family Residential (R-3) District must meet the requirements of Section 16 – Supplemental Regulations, and the following development standards:

703.01 Height Limits

No structure, shall be constructed or enlarged to exceed forty-five (45') feet in height.

703.02 Area Requirements

All lots shall meet the following requirements:

Lot Area: The minimum lot area per dwelling unit shall be five thousand (5,000) square feet.

Lot Width: One hundred (100') feet

Front Yard: Thirty (30') feet (See Supplemental Regulations – Section 1615 and Section 1616)

Side Yard: Ten (10%) percent of lot width or ten (10') feet, whichever is less

Rear Yard: Thirty-five (35') feet

703.03 Minimum Floor Area for all Dwellings:
1000 sq. ft. for a single dwelling
500 sq. ft. for two and multiple-family dwellings

703.04 Minimum Width and Depth for all Dwellings:
Twenty-two (22') feet

SECTION 8

MHP MANUFACTURED HOME PARK DISTRICT

800 PURPOSE

The purpose of the MHP Manufactured Home Park District is to establish areas suitable for the placement of manufactured housing and mobile homes as defined in this Resolution. No mobile home, manufactured home, trailer or similar portable residence shall be permitted to locate in the Township except in a Manufactured Home Park District.

801 PERMITTED USES

The following uses are permitted in the MHP district:

Accessory uses and accessory structures
Manufactured home (see Section 27 – Definitions)
Mobile home
Recreational facility, outdoor

802 SPECIAL USES

The following uses may be approved pursuant to Section 22 – Procedures & Requirements for Special Uses:

Telecommunication tower (See Supplemental Regulations – Section 1613)

803 APPROVAL PROCEDURE

Manufactured homes and manufactured home parks shall be located only in the MHP district and shall be developed according to the standards and regulations stated in this Section. The procedure to amend the Official Zoning Map to establish an MHP District is set forth in Section 23 – Zoning Changes and Text Amendments. Manufactured home parks are subject to the requirements of Section 19 – Site Plan Review, and shall conform to the following standards:

1. The proposed site shall be a minimum of ten (10) acres;
2. Public water and sanitary sewer shall be utilized by the development;
3. The maximum density shall not exceed four (4) manufactured home units per acre;
4. An adjacent yard not less than one thousand (1,000) square feet shall be provided for each manufactured home unit and shown on the site plan;
5. Two (2), 9x20 foot off-street parking spaces of concrete or asphalt shall be required for each manufactured home unit in addition to outdoor living area set forth in provision 4.
6. A minimum of forty-five (45') feet of clearance shall be provided between the individual manufactured and mobile homes.

SECTION 9

C-1 NEIGHBORHOOD COMMERCIAL DISTRICT

900 PURPOSE

The purpose of the Neighborhood Commercial (C-1) District is to provide areas for small local businesses that provide goods and services, not requiring outdoor sales, to the local neighborhood.

901 PERMITTED USES

The following uses are permitted in the C-1 Zoning District:

- | | |
|---|--|
| Accessory uses and accessory structures | Photo, dance, music studio |
| Bank or financial center | Professional office |
| Caterer | Restaurant (without drive-thru or delivery service) |
| Church or place of worship | Retail sales (less than 5,000 sq.ft. in floor area) |
| Day care facility | Self-service storage (see Supplemental Regulations Section 1623) |
| Funeral home | Veterinary office |
| Medical/dental office/clinic | |
| Personal service | |

902 SPECIAL USES

The following uses may be approved pursuant to Section 22 – Procedures & Requirements for Special Uses:

- | | |
|--------------------------|--|
| Assisted living facility | Gasoline sales |
| Club | Medical Marijuana Dispensary |
| Dwelling, accessory | Nursing home
(Rev 12-20-17, Z28-C142) |

903 DEVELOPMENT STANDARDS

All buildings, structures, lots, and land uses within the Neighborhood Commercial (C-1) District must meet the requirements of Section 16 – Supplemental Regulations, and the following development standards:

903.01 Height Limits

No structure, shall be constructed or enlarged to exceed thirty-five (35') feet in height.

903.02 Coverage & Setback Requirements

All lots shall meet the following requirements:

Lot Width: Eighty (80') feet

Lot Area: One (1) acre

Maximum Lot

Coverage: Seventy-five (75%) percent

Front Yard: Thirty-five (35') feet (See Supplemental Regulations – Section 1615 and Section 1616)

Side Yard: Twenty (20') feet (See Supplemental Regulations–Section 1614)

Rear Yard: Thirty (30') feet (See Supplemental Regulations – Section 1614)

SECTION 10

C-2 GENERAL COMMERCIAL DISTRICT

1000 PURPOSE

The purpose of the General Commercial (C-2) District is to provide areas for general commercial uses serving a regional area.

1001 PERMITTED USES

The following uses and similar uses as interpreted by the Zoning Inspector are permitted in the General Commercial (C-2) District:

Agricultural products/implement sales/service	Manufactured homes sales
Accessory uses and accessory structures	Marine sales and service
Amusement arcade	Medical Marijuana Testing Laboratory
Automobile body shop	Medical/dental office/clinic
Bank and financial center	Meeting or reception hall
Bar/lounge/tavern	Motor vehicle/recreational vehicle storage yard
Business school	Motor vehicle sales/service/rental
Car/truck wash	Movie theater
Caterer	Offices
Church or place of worship	Parking lots without a main building
Club	Personal service
Commercial fishing operations (See Supplemental Regulations - Section 1610)	Photo, dance, art, music studio
Day care facility	Professional office
Flea markets/auction markets	Recreation facilities and sales
Funeral home	Restaurant (with or without drive-thru or delivery)
Gasoline sales	Retail sales
Hospital	Self-service storage (See Supplemental Regulations – Section 1623)
Hotel/motel/lodging house	Sexually oriented businesses (See Supplemental Regulations – Section 1612)
Lawn/tree service (See Supplemental Regulations – Section 1627)	Veterinary offices
	Watercraft storage (Rev 12-20-17, Z28-C142)

1002 SPECIAL USES

The following uses may be approved pursuant to Section 22 – Procedures & Requirements for Special Uses:

Medical Marijuana Dispensary
(Rev 12-20-17, Z28-C142)

1003 DEVELOPMENT STANDARDS

All buildings, structures, lots, and land uses within the General Commercial (C-2) District must meet the requirements of Section 16 – Supplemental Regulations, Section 1400 – State Route 2 Overlay District if located along State Route 2, and the following development standards:

1002.01 Height Limits

No structure, shall be constructed or enlarged to exceed forty-five (45') feet in height.

1002.02 Trip Generation

All uses generating one hundred (100) or more peak hour trips (consistent with the Institute of Transportation Engineers (ITE) General Manual) shall submit a Traffic Impact Study.

1002.03 Coverage & Setback Requirements

All lots shall meet the following requirements:

Lot Area: One (1) acre

Lot Width: One hundred twenty-five (125') feet

Lot Coverage: Seventy-five (75%) percent

Side Yard: Twenty (20') feet (See Supplemental Regulations – Section 1614)

Rear Yard: Thirty-five (35') feet (See Supplemental Regulations – Section 1614)

Front Yard: Fifty (50') feet (See Supplemental Regulations – Section 1615 and Section 1616)

SECTION 11

R-C Recreational Commercial District

1100 PURPOSE

The purpose of the Recreational Commercial (R-C) District is to establish areas which are appropriate for the recreational businesses of Jerusalem Township.

1101 PERMITTED USES

The following uses are permitted in the Recreational Commercial (R-C) Zoning District:

Accessory uses	Fuel/gasoline sales
Commercial fishing operations (See Supplemental Regulations Section – 1610)	Marina
Community pool (See Supplemental Regulations – Section 1617.02)	Marine sales and service
Fishing equipment sales	Public service facilities
	Recreational facilities and sales
	Recreational vehicle and vessel storage
	Retail sales (less than 5,000 sq.ft. in floor area)
	Watercraft storage

1102 SPECIAL USES

The following uses may be approved pursuant to Section 22 – Procedures and Requirements for Special Uses:

Campground/RV parks

1102 DEVELOPMENT STANDARDS

All buildings, structures, lots, and land uses within the Recreational Commercial (R-C) District must meet the requirements of Section 16 – Supplemental Regulations, and the following development standards:

1102.01 Height Limits

No structure shall be constructed or enlarged to exceed three stories of forty-five (45') feet in height.

1102.02 Trip Generation

All uses generating one hundred (100) or more peak hour trips (consistent with the Institute of Transportation Engineers (ITE) Generation Manual) shall submit a Traffic Impact Study.

1102.03 Coverage & Setback Requirements

All lots shall meet the following requirements:

Lot Area: One (1) acre

Lot Width: Eighty (80') feet

Lot Coverage: Seventy-five (75%) Percent

Front Yard: Fifty (50') feet (See Supplemental Regulations – Section 1615 and Section 1616)

Side Yard: Twenty (20') feet (See Supplemental Regulations – Section 1614)

Rear Yard: Thirty (30') feet (See Supplemental Regulations – Section 1614)

SECTION 12

M-1 INDUSTRIAL DISTRICT

1200 PURPOSE

The purpose of the Industrial (M-1) District is to provide areas for industrial uses.

1201 PERMITTED USES

The following uses are permitted in the Industrial (M-1) Zoning District:

- | | |
|---|--|
| Accessory uses and structures | Manufacturing |
| Assembly of electrical components, instruments, and devices, including electroplating | Medical Marijuana Cultivator |
| Building material sales yard | Medical Marijuana Processor |
| Commercial food preparation | Medical Marijuana Testing Laboratory |
| Contractor yard/storage | Oil or gas wells |
| Distribution center | Plumbing, sheet metal, and woodworking shops |
| Equipment sales & rental | Professional office/services |
| Laundry/dry cleaning plant | Self-service storage facility (See Supplemental Regulations – Section 1623) |
| Lawn/tree service (See Supplemental Regulations – Section 1627) | Storage lot including automobiles, watercraft, trucks, and recreational vehicles (See Supplemental Regulations – Section 1628) |
| Lumber yard (provided saws, planers, processing machines are within a completely enclosed building) | Truck repair garage |
| Machine shop | Wholesaling, including the storage, handling, or sale of merchandise primarily to retailers |
| Manufactured home sales | |

(Rev 12-20-17, Z28-C142)

1202 SPECIAL USES

The following use may be approved pursuant to Section 22 – Procedures & Requirements for Special Uses:

- | | |
|--|---|
| Asphalt/concrete production | Motor vehicle salvage yards (see Supplemental Regulations – Section 1620) |
| Day care center | Recycle center |
| Landfill | Restaurant |
| Logging/wood storage | Solid waste disposal |
| Mineral extraction (see Supplemental Regulations – Section 1604) | Truck terminal |

1203 DEVELOPMENT STANDARDS

All buildings, structures, lots, and land uses within the Industrial (M-1) District must meet the requirements of Section 16 – Supplemental Regulations, and the following development standards:

1203.01 Height Limits

No structure shall be constructed or enlarged to exceed sixty (60') feet in height.

1203.02 Trip Generation

All uses generating one hundred (100) or more peak hour trips (consistent with the Institute of Transportation Engineers (ITE) Generation Manual) shall submit a Traffic Impact Study.

1203.03 Coverage & Setback Requirements

All lots shall meet the following requirements:

Lot Area: One (1) acre

Lot Width: One hundred seventy-five (175') feet

Lot Coverage: Seventy-five (75%) Percent

Front Yard: Fifty (50') feet (See Supplemental Regulations – Section 1615 and Section 1616)

Side Yard: Thirty-five (35') feet (See Supplemental Regulations – Section 1614)

Rear Yard: Forty (40') feet (See Supplemental Regulations – Section 1614)

SECTION 13

PLANNED UNIT DEVELOPMENT

1300 PURPOSE

The Planned Unit Development (PUD) is a voluntary procedure that provides an overlay zoning district that is intended to encourage innovative design, conservation of significant natural features such as those found near the shores of Lake Erie, consolidation of open space and a combination of uses with an integrated design. The Planned Unit Development allows greater design flexibility so that natural features and open space may be preserved and enhanced, and development concentrated in a coordinated and efficient manner.

1301 DESCRIPTION

The Planned Unit Development may be a residential, commercial, or industrial development or may be a combination of uses with no minimum site area required. Where a combination of uses are proposed, a maximum of twenty-five (25%) percent of the total acreage may be developed with uses not permitted in the underlying zoning district. The Board of Township Trustees shall review and may find that the combination of uses meet the standards set forth in Section 1304. Signs for uses developed pursuant to the twenty-five (25%) percent provision, shall conform to the District in which the use is permitted and subject to Section 18 – Signs and Outdoor Advertising of this Resolution.

1302 PROCEDURE

The Planned Unit Development shall be submitted and processed pursuant to Section 22 – Zoning Changes and Text Amendments. The applicant shall submit a "Request for Zoning Change" application with twenty (20) copies of the development plan along with the required application fee. The application shall include the following:

1302.01 General Information

- A. Name, address and phone number of the applicant;
- B. Name and address of registered surveyor, engineer and/or landscape architect who prepared the plan;
- C. Legal description of the property;
- D. Present use of the property;
- E. Conceptual overview of the development;
- F. Proposed provision of utilities;
- G. Proposed ownership and maintenance of common open space;
- H. Anticipated timing and phasing of the development.

1302.02 Development Plan Information

- A. A vicinity/project location map;
- B. Location, type and density of development types;
- C. Conceptual drainage plan;
- D. Location and amount of open space(s);
- E. Gross lot acreage, net lot acreage, maximum allowable density, proposed density with calculations indicated;
- F. Maximum site coverage (not required for detached single-family PUD's)
- G. Topography at two foot contour intervals;
- H. Existing features of the development site, including major wooded areas, streets, easements, utility lines, and land uses;
- I. Street layout and names;
- J. Existing buildings to remain or to be removed, and if the existing buildings remain, indicate proposed use;
- K. All proposed signs excluding street signs;
- L. Proposed method of street lighting;
- M. Landscape material to be used and proposed locations;
- N. Location, area, and dimensions of all lots, setbacks, and building envelopes;
- O. Required number of parking spaces and number of spaces proposed.

1303 ADDITIONAL INFORMATION

The Board of Township Trustees, Zoning Commission, and/or Zoning Inspector may require additional information such as professionally prepared maps, studies or reports including environmental assessments and/or traffic impact studies for the development. The expense for this information is the responsibility of the applicant.

1304 STANDARDS

1304.01 General

- A. The development shall be in conformance with the goals & objectives of the Jerusalem Township Land Use Plan of March 2001, the Zoning Resolution and the Lucas County Subdivision Regulations (and as amended);
- B. The uses are compatible with the proposed and existing surrounding land uses;
- C. The arrangement of land uses and buildings on the site integrate the topography, natural features, views, traffic access and the arrangement of usable common open space.

1304.02 Specific – Residential

- A.** The maximum number of dwelling units (DU's) permitted for the site is listed in the districts below. An additional dwelling unit is permitted in each district subject to each additional acre provided within the Planned Unit Development as common and consolidated open space. Consolidated open space may include recreation areas, ponds/lakes, and natural areas.

A/R District

1 DU for per
acre of land

R-1 District

2.9 DU's per
acre of land

R-3 District

6.9 DU's per
acre of land

- B.** No more than fifty (50%) percent of gross site acreage shall be devoted to coverage by buildings, structures, street pavement, driveway pavement, and parking area pavement;
- C.** No less than twenty (20%) percent of the gross site acreage, none of which is part of any yard or perimeter open space, shall be allocated to usable, accessible and consolidated, common open space and may be allocated on a plat by plat basis;
- D.** An open space area void of buildings, structures, parking areas, or other above-ground improvements shall be maintained along all perimeter property lines of the Planned Unit Development as follows:
- 1.** When abutting A/R, R or OS/P Districts, the open space perimeter area shall be provided that has a minimum depth equal to the required rear yard setback of the PUD's underlying zoning district;
 - 2.** When a residential area of a Planned Unit Development abuts a C, R/C, or "M" District, a open space perimeter area shall be provided that has a minimum depth of fifty (50') feet;
- E.** Building height shall be in accordance with the underlying zoning.
- F.** There may be no minimum lot size, lot-width, building or structure setback requirements except as provided in Section 1304.02(D) and Section 1615 and Section 1616.
- G.** Telephone, electrical, trash receptacle area(s), cable, and other utility appurtenances shall be screened.

1304.03 Specific – Commercial/Industrial

- A.** Commercial/industrial developments shall be planned with common parking areas and common points of ingress and egress. Parking requirements shall be provided pursuant to Section 21 – Parking Requirements, and the number of spaces required shall be determined by each specific use within the Planned Unit Development;
- B.** An open space area void of buildings, structures, parking areas, or other above-ground improvements except fencing shall be maintained on all perimeter property lines of the Planned Unit Development:
 - 1.** A minimum open space depth of thirty (30') feet shall be provided unless a greater setback is required as listed in the underlying zoning district;
 - 2.** A minimum open space distance of fifty (50') feet shall be provided when abutting an A/R or R District;
- C.** No less than twenty (20%) percent of the gross lot acreage, none of which shall be a part of any yard, shall be allocated to usable, accessible and consolidated, common open space;
- D.** No more than seventy (70%) percent of gross site acreage shall be devoted to coverage by buildings, structures, street, driveway and parking area pavement;
- E.** Landscaping or screening for parking shall be required pursuant to Section 19 – Landscaping Requirements;
- F.** There shall be no minimum lot size, lot-width, or building, or structure setback requirements except as provided in Section 1304.03 (B) and Section 1615 and Section 1616;
- G.** Telephone, electrical, trash receptacle area(s), cable, and other utility appurtenances shall be sufficiently screened.

1305 CHANGE TO APPROVED PLAN

Changes or alterations to the development plan as approved by the Board of Township Trustees may be administratively reviewed and approved by the Zoning Inspector, except in the following circumstances:

- A.** Change in the overall acreage of the Planned Unit Development;
- B.** Any change in use in the Planned Unit Development;
- C.** Substantial alteration to open space areas and their location(s);
- D.** A significant change in street pattern;
- E.** A significant change in the landscape plan;
- F.** An increase in the number of buildings;
- G.** Changes in the building/buildings envelope location(s).

In those instances where changes to the approved plan are not administratively approved by the Zoning Inspector, the Board of Township Trustees shall hold a public hearing to consider such changes.

1306 EXPIRATION AND EXTENSION OF APPROVAL PERIOD

If construction of any phase of the approved Planned Unit Development begins within two (2) years after approval is granted, the approval shall be valid until the development is completed. If no construction has begun within two (2) years after the approval is granted, the Planned Unit Development shall be void and the land shall revert to the district regulations in which it is located. An extension of the time limit may be approved by the Board of Township Trustees.

SECTION 14

STATE ROUTE 2 (JERUSALEM ROAD) OVERLAY DISTRICT

1400 **Purpose and Intent**

The purpose of the State Route 2 Overlay District is to promote and protect the public health, safety, comfort, convenience and general welfare by providing for consistent and coordinated treatment of the properties bordering State Route 2 in Jerusalem Township. State Route 2 is a major east-west route through Jerusalem Township that links the Toledo Metropolitan area with the metropolitan areas to the east. State Route 2 is a regionally significant roadway that serves as a major corridor as the surrounding areas continue to grow and develop. The State Route 2 Overlay District provides standards and requirements intended to preserve the environmental and aesthetic qualities of the corridor and manage access to property in a manner that will maintain traffic safety and roadway capacity.

1401 **State Route 2 Overlay District Boundaries**

The boundaries of the District are hereby established as shown on the Jerusalem Township zoning maps. The District includes those parcels with frontage along the State Route 2 right-of-way to a depth of six hundred (600') feet from the centerline of the right-of-way along both sides, extending from the City of Oregon to the west to Ottawa County to the east.

1402 **Review and Approval Procedures**

Site plan review and approval is required for all new development, for any change of use, and for any existing structure that is enlarged by fifty (50%) percent or more or when the enlargement contains five thousand (5,000) square feet or more in floor area. One and two-family dwellings are exempt from the site plan review requirements. The site plan review shall be as specified in Section 18 of this Zoning Resolution. In addition, the Ohio Department of Transportation (ODOT) requires a driveway access permit application for any new or modified access, as well as for a change in use for existing driveways. ODOT requires a traffic impact study for any proposed use that generates greater than one hundred (100) trips per peak hour.

1403 **Permitted and Special Uses**

All uses which are permitted or special uses in the underlying zoning district(s) are allowed in the Overlay District, except those uses expressly **prohibited**.

1404 **Prohibited Uses**

Auction market with outdoor display and/or storage
Flea market
Manufactured home, mobile home or industrialized dwelling unit sales
Manufactured home park
Motor vehicle/watercraft salvage yard/junk yard
Off-premises sign
Pole sign
Roof sign

1405

Accessory Buildings and Uses

All accessory buildings and uses which are permitted in the underlying zoning district(s) are permitted within the district, except that any detached accessory building on any lot shall have on all sides the same architectural features or shall be architecturally compatible with the principal building(s) with which it is associated. Accessory buildings used for residential or agricultural purposes are exempt from this requirement.

1406

Development Standards

1406.1 Minimum Front Yard Setback

The minimum front yard setback along State Route 2 shall be the greater of fifty (50') feet from the right-of-way line or one hundred fifty (150') feet from the centerline of State Route 2. Parcels with frontage on more than one street shall have a minimum front yard setback from the right-of-way line of the minor street of fifty (50') feet.

1406.2 Minimum Side Yard Setback

As specified in the underlying zoning district.

1406.3 Minimum Rear Yard Setback

As specified in the underlying zoning district. In addition, a twenty-five (25') foot rear yard landscape area shall be provided for any commercial or industrial use where the rear yard abuts an agricultural or residential zoning district outside the overlay district.

1406.4 Maximum Building Height

As specified in the underlying zoning district.

1406.5 Minimum Front Yard Landscape Area

Thirty (30') feet along State Route 2 and ten (10') feet along side streets. The landscape area shall be located within the front yard setback area(s) and no off-street parking shall be located within the landscape area. In those instances where a parallel service road is provided within the required front yard the minimum landscape area width shall be ten (10') feet. Residential and agricultural uses are exempt from this requirement.

1406.6 Lot Frontage

No existing lot that has frontage along State Route 2 may be subdivided in such a manner so as to reduce such frontage to less than two hundred (200') feet. Existing lots of record at the time of this amendment's adoption with widths less than two hundred (200') feet retain their legal non-conforming status.

- 1407 Access to Individual Parcels**
Access along State Route 2 shall be reviewed relative to the distance from other drive approaches and from roadway intersections. Access shall be reviewed by the Lucas County Engineer and the Ohio Department of Transportation prior to approval. When deemed appropriate by the Lucas County Engineer, the Ohio Department of Transportation, or the Jerusalem Township Zoning Inspector, the developer may be required to prepare a traffic impact study or a traffic assessment study.
- 1408 Access Permits**
All access permits shall be reviewed and approved by the Ohio Department of Transportation. Design and location of access driveways along State Route 2 shall be in compliance with applicable ODOT guidelines and regulations.
- 1409 Access Options**
The preferred method of providing access to parcels is to reduce or eliminate driveways and curb cuts by using front access drives (frontage roads), rear access drives, cross access easements and shared drive approaches. When parcels abut more than one roadway, the preferred access option is to locate access points on less-traveled roadways.
- 1410 Traffic Impact Study**
If required by the Lucas County Engineer, the Ohio Department of Transportation, or the Jerusalem Township Zoning Inspector, a traffic impact study shall be prepared by a qualified Professional Engineer at the developer's expense. The study shall investigate the feasibility and benefits of improvements such as signals, turn lanes, driveway movement limitations, etc. to protect the safety and welfare of the traveling public. The traffic impact study shall include the following elements:
1. A description of the site and study area.
 2. Anticipated development of adjacent parcels.
 3. Trip generation and distribution.
 4. Traffic assignment resulting from the development.
 5. Projected future traffic volumes.
 6. An assessment of the impact resulting from driveway alternatives.
 7. Recommendations for site access and transportation improvements needed to maintain traffic flow at an acceptable and safe level of service.
 8. An evaluation of the effects the proposed development will have on the level of service and road capacity.
- 1411 Traffic Assessment Study**
In lieu of a Traffic Impact Study, the Lucas County Engineer, the Ohio Department of Transportation, or the Jerusalem Township Zoning Inspector may request a Traffic Assessment Study to accompany the site plan for review and consideration. The following information shall be included with the Traffic Assessment Study:

1. Proposed and/or existing building size and use, driveways, parking areas, and drive aisles;
2. Current use, parking areas, drive aisles and driveways form all properties apposite and adjacent the proposed site;
3. Road details including public right-of-way within the limits of the traffic impact, including the number and type of vehicular traffic lanes, traffic signal locations, and traffic control signs such as stop and yield;
4. Anticipated daily and peak hour traffic volumes at site access points.

1412 Architectural Review Requirements

Site plan review shall include review of architectural design elements. The architectural design of buildings within the State Route 2 Overlay District shall include the consideration of the following elements:

1. Scale and proportion;
2. Suitability of building materials;
3. Design in relation to surrounding buildings;
4. Design in relation to proposed landscaping; and
5. Aesthetics of the proposed building.

1413 Landscape Review Requirements

Site plan review shall also include the review of landscape design elements and conformance with all applicable requirements. Landscape requirements shall be in conformance with Section 20 of this Resolution.

SECTION 15

RIPARIAN SETBACKS (REV. 10-13-20, Z28-C145)

1500 Purpose

Riparian Setbacks Floodplains perform crucial roles in preventing flooding by storing runoff water, and benefiting water quality by providing riparian habitat. It is the intent of these standards to establish riparian setbacks that will protect floodplains. Therefore, riparian setbacks shall be measured outward from the ordinary high water mark on each side of a stream, except as follows.

1501 Riparian Setbacks

Exceptions

- a) Where the 100-year floodway is wider than the riparian setback on either side or both sides of the stream, the riparian setback shall be extended to the outer edge of the 100-year floodway.
- b) In cases where the required setback cannot be met because the depth of the parcel would render it unbuildable, then a reduction in the setback could be granted by the Township Board of Zoning Appeals.

Widths of riparian setbacks are measured as horizontal map distances on each side of a stream, and are established as follows:

- a) A minimum of 300 feet on each side of all streams draining an area greater than 300 square miles.
- b) A minimum of 100 feet on each side of all streams draining an area greater than 20 square miles and up to 300 square miles.
- c) A minimum of 40 feet on each side of all streams draining an area greater than 3 square miles (>1920 acres) and up to 20 square miles.
- d) A minimum of 30 feet on each side of all streams draining an area less than 3 square miles (<1920 acres).

1502 Permitted Uses

- a) Recreational Activity - Passive recreational uses, as permitted by federal, state, and local laws, such as hiking, non-motorized bicycling, fishing, hunting, picnicking and similar uses and associated structures including boardwalks, pathways, boat docks and ramps constructed of pervious material, picnic tables, and wildlife viewing areas.
- b) Removal of Damaged or Diseased Trees - Damaged or diseased trees may be removed. Because of the potential for felled logs and branches to damage downstream properties and/or block ditches or otherwise exacerbate flooding, logs and branches resulting from the removal of damaged or diseased trees that are greater than 6 inches in diameter, should be anchored to the shore or removed from the 100-year floodplain.

- c) Revegetation and/or Reforestation - Species of native plants recommended for stabilizing flood prone areas along streams and ditch within the County of Lucas are listed in the Best Management Practices appendix.
- d) Right of Access by Jerusalem Township/County Engineer - Jerusalem Township or Lucas County Engineer maintains the right of access to all streams and ditches within the jurisdiction for the purposes of maintenance and improvements to alleviate flooding.

1503 Wetland within Riparian Setback Areas

- a) A 120 foot setback extending beyond the outer boundary of a Category 3 Wetland.
- b) A 75 foot setback extending beyond the outer boundary of a Category 2 Wetland.
- c) No additional setback will be required adjacent to Category 1 Wetland

Wetlands should be delineated by a qualified professional under guidelines established by the US Army Corps of Engineers and Ohio Environmental Protection Agency and the site delineation approved by the appropriate agencies. All Wetland delineations would also include the latest version of the Ohio Rapid Assessment Method for wetland evaluation approved at the time of application of the regulations.

The applicant shall be responsible for delineating the Riparian Setback, including any expansions or modifications as required by the Township hereof, and identifying this setback on all subdivisions, land development plans, and/or building permit applications. This delineation shall be done at the time of application of the preliminary plans, or all plans that are required, or at the time of submission of any permit applications. This delineation shall be subject to review and approval by the Jerusalem Township. As the result of this review, Jerusalem Township may require further studies from the applicant.

Prior to any soil disturbing activity, the Riparian Setback shall be clearly delineated with construction fencing or other suitable material by the applicant on site, and such delineation shall be maintained throughout soil-disturbing activities. The delineated area shall be maintained in an undisturbed state unless otherwise permitted by these regulations. All fencing shall be removed when a development project is completed.

1504 The following uses are permitted within the Riparian Setbacks with prior approval of the design

- a) Stream bank Stabilization/Erosion Control Measures - Best Management Practices (BMPs) for stream bank stabilization or erosion control may be allowed if such practices are within permitted uses by the local, state, and federal government regulations and ecologically compatible and emphasize the use of natural materials and native plant species where practical and available. Such stream bank stabilization/ erosion control practices should only be undertaken upon approval of a Stormwater Pollution Prevention Plan (SWPPP or SWP3) by the local reviewing agency and should follow the recommendations of the most recent version of the Ohio EPA's Rainwater and Land Development Manual.

- b) Stream crossings or Crossings of streams through the Riparian Setback by vehicles, storm sewers, sewer and/or water lines, and public utility lines will be per the approval of local, county, and state governing agencies and as a part of the regular subdivision process. Roadway crossings must be built in accordance with local regulations.
- c) Placement of stormwater retention or detention facilities may be considered within the Riparian Setback if stormwater quality treatment is consistent with state standards (most current version of the Ohio EPA general construction permit).

1505 Uses Prohibited in the Riparian Setback

- a) Structures - There should be no structures of any kind except as permitted under these regulations.
- b) Dredging or Dumping - There should be no drilling for petroleum or mineral products, mining activity, filling or dredging of soil, spoils, or any material— natural or man-made— except as permitted under these regulations.
- c) Drainage Alterations - Except as necessary to maintain the bed elevation or flow line of the channel in the event of aggradation, there should be no manipulation or alteration of wetlands, creeks, streams, surface or subsurface springs or other bodies of water, or any activities on, or uses of, the property that may be detrimental to the aquatic or terrestrial ecosystems of the property. The owner may conduct periodic inspections in collaboration with local drainage authorities to measure the bed elevation or flow line of the water course. Steps to restore original hydraulic capacity and original grade may be taken in situations where local drainage authorities have determined that lowered bed elevation or flow line and aggradation impede subsurface drainage outlets or threaten to cause flood damage to buildings or roads.
- d) Roads or Driveways - There should be no roads or driveways, except as permitted under these regulations.
- e) Motorized Vehicles - There should be no storage of motorized vehicles of any kind, except as permitted under these regulations.
- f) Modification of Natural Vegetation - Modification of the natural vegetation should be limited to conservation maintenance that the landowner deems necessary to control noxious weeds; for plantings consistent with the policies of the local reviewing agency; for disturbances approved by these agencies; and for the passive enjoyment, access and maintenance of landscaping or lawns.
- g) Impervious Surfaces - There should be no parking lots or other human-made impervious cover, except as permitted under these regulations.

1506 Sewage Disposal or Treatment Areas

Riparian Setbacks shall not be used for the disposal or treatment of sewage except for:

- a) Undeveloped parcels that have received site evaluation approval and/or permit approval prior to the enactment of this chapter.
- b) Dwellings served by disposal/treatment systems existing at the time of passage of these regulations when such systems are properly sited (approved site evaluation) and permitted or in accordance with the Lucas County Health Department and/or the Ohio Environmental Protection Agency. Existing failing systems which are located within the Riparian Setback can be upgraded with approval of the Lucas County Health Department and / or the Ohio Environmental Protection Agency.

1507 Non-conforming Structures or Uses in the Riparian Setback

- a) Structures and uses within the Riparian Setback, existing at the time of approval of the Riparian Setback plan, that are not permitted under these provisions may be continued but should not be expanded except as set forth in this Section.
- b) If damaged or destroyed, these structures or uses may be repaired or restored in accordance with Section 17 – Non-Conformity:
 - A. In the event that any non-conforming building, structure, or mobile, manufactured or modular home is destroyed by any means to the extent or more than sixty (60%) percent of the cost of replacement of such structure, exclusive of foundation, it shall not be rebuilt, restored, or reoccupied for any use unless it conforms to all regulations of this Resolution and the following conditions:
 - 1) A Zoning Certificate for such restoration shall be first obtained within one (1) year of such damage or destruction;
 - 2) Such repair shall not cause a new or additional non-conformity and such repair shall not increase the size, dimension or intensity of non-conformity that existed prior to such damage or destruction.
- c) A residential structure or use within the Riparian Setback existing at the time of approval of the Riparian Setback plan may be expanded subject to the following provisions:
 - 1) The expansion conforms to existing zoning regulations.
 - 2) The expansion must not exceed an area of 15% of the total footprint of existing structure or use that lies within the Riparian Setback. Expansions exceeding 15% of the total footprint within the Riparian Setback must be obtained through the variance process.
 - 3) Non-residential structure or use expansions will be permitted only through the Jerusalem Township variance process.

1508 Boundary Interpretation and Appeals Procedure

- a) When an applicant disputes the boundary of the Riparian Setback or the ordinary high water mark of a stream, the landowner or applicant should submit evidence to the Lucas Soil and Water Conservation District (SWCD) that describes the boundary, presents the landowner or applicant's proposed boundary and presents all justification for the proposed boundary change.
- b) Lucas SWCD should evaluate all materials submitted and should make a written recommendation to the Township Board of Zoning Appeals or the Toledo-Lucas County Plan Commissions within a reasonable period typically not to exceed 45 days. A copy of this recommendation should be submitted to the applicant. If during this evaluation the Lucas SWCD requires further information to complete this evaluation, he or she may be required to provide this information.
- c) The Township Board of Zoning Appeals should decide such boundary disputes. The party contesting the location of the Riparian Setback or the ordinary high water mark of the streams as determined by these regulations should have the burden of proof in case of any such appeal.

1509 Variances within Riparian Setback

- a) Applications for variances should be submitted to the Township Board of Zoning Appeals.
- b) The Township Board of Zoning Appeals should consult with representatives from the Lucas Soil and Water Conservation District (SWCD), Ohio Department of Natural Resources; the Ohio Environmental Protection Agency, Division of Surface Water; the Lucas County Engineer; the Lucas County Health Department; or other technical experts as necessary to consider variance requests.
- c) No variances should be granted for expansion of the following structures or uses:
 - 1) Facilities which use, store, distribute, or sell petroleum-based products or any hazardous materials. Such facilities include, but are not limited to: asphalt plants, dry cleaners, gasoline service stations, and road maintenance facilities.
 - 2) Facilities which use, store, distribute, or sell products which may contribute higher than acceptable concentrations of dissolved or particulate matter to stormwater runoff around the facility. Such facilities include, but are not limited to: landfills or transfer stations, junk yards, recycling facilities, quarries and borrow pits, sand and gravel extraction operations, and road salt storage barns.
 - 3) In reviewing whether to grant variances, the Township Board of Zoning Appeals should consider the purpose and intent of the setback alteration, exceptional circumstances, undue hardship, and the extent of the alteration.

1510 Inspection of Riparian Setback

- a) The applicant should notify Jerusalem Township, Lucas Soil and Water Conservation District (SWCD) and the Lucas County Engineers Office at least seven days prior to land disturbing activities. Jerusalem Township and the Lucas County Engineers Office may enter the affected parcels from time to time to conduct on-site inspections to ensure compliance with this regulation.
- b) The Riparian Setback should also be inspected annually or as time permits by the Lucas Soil and Water Conservation District (SWCD) and the Lucas Engineers Office or approved monitoring entity for compliance with any approvals under these regulations or at any time evidence is brought to the attention of the Township that uses or structures are occurring that may reasonably be expected to violate the provisions of these regulations.

1511 Applicability, Compliance and Violations

- a) The provision of this Section shall apply to all lands and zoning districts within unincorporated areas under the jurisdiction of Jerusalem Township.
- b) No preliminary plan, building, or zoning approvals shall be issued by Jerusalem Township without full compliance with the terms of these regulations where applicable.
- c) Any person or organization that violates this Section shall be guilty of a minor misdemeanor and, upon conviction thereof, shall be subject to punishment as provided in Section 2400 of the Jerusalem Township Zoning Resolution and required to restore the Riparian Setback through a plan approved by the Township.

SECTION 16

SUPPLEMENTARY REGULATIONS

1600 GENERAL

In addition to the Zoning District requirements, the following Supplementary Regulations shall regulate uses and structures in Jerusalem Township.

1601 ACCESSORY BUILDING OR STRUCTURE

An accessory building or structure shall be subject to the following requirements:

1. It shall have a minimum setback of five (5') feet from all lot lines, it shall be located a minimum of five (5') feet from the main building, and it shall be located outside of the right-of-way and all utility easements. The setback shall be measured from the outermost projection of building.
2. It shall not be located in any front yard nor in the side yard of a corner lot when that yard faces a street or road.
3. It shall not exceed twenty four (24') feet in height and may not occupy more than thirty (30%) of the required rear yard.
4. No accessory use, building, or structure shall be permitted on any lot which does not have a dwelling or a main building on it, except within the OS/P District.
5. Exceptions:
 - A. Private bus shelters may be located in any yard, but shall not exceed twenty four (24) square feet in size and shall not exceed seven (7') feet in height.
 - B. An accessory building or structure may be permitted in a front yard or a side yard of a corner lot, when that yard faces a street or road, with the following requirements:
 - The minimum lot size shall be two (2) acres and have a minimum depth of five hundred (500') feet.
 - No accessory building or structure shall be located closer to the right-of-way than the required setback of the principal structure.

1602 ARCHITECTURAL PROJECTIONS

1. Chimneys may project into a required side yard setback not more than two (2') feet and may project into a required rear yard setback no more than four (4') feet.

2. Open, unenclosed stairways or steps not covered by a roof or canopy may extend or project into the required side yard setback not more than four (4') feet and may project into the required rear yard setback not more than six (6) feet. Open, unenclosed stairways or steps not covered by a roof or canopy shall not exceed six (6') feet in width.

1603 FENCES

Fences, plant material, earth mounds, and similar screening devices between the principal building and a street, are permitted provided that the height of such device does not exceed forty-two (42") inches in height as measured at the adjacent road grade and provided the material is not located within the public right-of-way. Fences to the rear or to the side of a principal building shall not exceed six (6') feet in height except in Commercial, or Industrial Districts in which case, no fence shall exceed eight (8') feet in height. Motor Vehicle Salvage Yards, baseball back stops, and tennis courts are allowed to have fencing not to exceed ten (10') feet in height. (See Supplemental Regulations Section 1620.05, and Section 1622E). All public recreational facilities are exempt from this requirement. No barbed wire or razor ribbon shall be used except for agricultural purposes.

1604 MINERAL EXTRACTION, STORAGE, PROCESSING, & MANUFACTURE

The following principles of acceptance, submission, and design requirements shall apply to mineral extraction and/or storage, processing and manufacturing activities. Mineral extraction may be permitted as Special Use in an M-1 Industrial District. In addition to the provisions of Section 22 – Procedures and Requirements for Special Uses, the following shall be considered in the review of a proposed Mineral Extraction, Storage, Processing, and Manufacturing Special Use request.

1604.01 Principles of Acceptance

In reviewing the location and the development plan of a proposed mineral extraction operation, the following general principles of acceptance shall be considered with respect to the particular location and the present and future development of the area.

- A. The mineral extraction operation shall not be detrimental to the adjacent land and surrounding area.
- B. Potential flooding shall not be increased for surrounding properties as a result of excavating or elevating portions of the property under consideration.
- C. The use and development of a proposed mineral extraction operation and its adjacent area shall be properly planned so as to prevent ground water contamination.
- D. After completion, the excavated area shall be properly maintained so that it will not become a danger and nuisance to area residents.

1604.02 Submission Requirements

The following items shall be submitted with the Special Use application:

- A. A topographical survey and soils report analysis of the property, prepared and sealed by a professional engineer, surveyor, or geologist.
- B. A site plan drawn to scale showing the location of the proposed excavated area, final grades, location of any existing or proposed buildings, septic tanks, leach fields, wells, easements, ditches, and utility lines within five-hundred (500') feet of the perimeter of the area.
- C. General location map.
- D. Location of haul roads on the property and proposed truck routes to the property.
- E. A drainage plan indicating the directional flow of water, constructed drainways, holding canals, natural waterways used for drainage, and the streams or tributaries receiving this discharge.
- F. A reclamation plan of the area to be affected, including a specific reuse of the property upon completion of the excavation.

1604.03 General Conditions and Design Requirements

The mineral extraction operation shall be conducted in accordance with the following conditions:

- A. A minimum site area of twenty-five (25) acres.
- B. The excavated area shall be a minimum of five (5) acres not to exceed twenty (20%) percent of the total site area.
- C. The excavated area shall have a one hundred (100') feet minimum setback from any public road right-of-way.
- D. Excavated areas shall be no closer than three hundred (300') feet from septic tanks, water wells and leach fields in accordance with Health Department Standards.
- E. If the reclamation of the site includes a pond, the pond shall have a minimum depth of seventeen (17') feet. Within fifteen (15') feet of the shoreline, the average slope of the submerged areas of the pond shall be no steeper than 3 to 1. From the shoreline away from the water, the grade shall be no steeper than 4 to 1 within twenty (20') feet of the shoreline.
- F. No materials shall be hauled to the property for use as fill, except for clean clay material which may be required for a lake or other materials(s) approved by the Ohio Department of Natural Resources.

- G.** An appropriate amount of top soil must be left on the site in order to establish and maintain vegetation.
- H.** In areas where sanitary sewers are not available, backfilling for any proposed housing pad site and leach field areas as shown on the reclamation plan shall be distributed in accordance with Health Department Standards. The topsoil on a proposed housing site shall be stripped and stored, then the area backfilled and compacted with the excavating material, the topsoil replaced over the backfilled area(s), and final grading completed.
- I.** All backfilling and excavating material distribution shall be certified in writing to the Township Zoning Inspector as conforming to the site grading plan and reclamation plan. The written certification shall be submitted by a professional engineer or surveyor and shall be submitted at the time of completion or in phases as required by the provisions of the Special Use approval.
- J.** Any areas not backfilled must be drained with ditches, which must include culverts under all driveways to eliminate any standing water.
- K.** All haul roads shall be properly maintained to control dust, and shall have a gate to control ingress and egress. All truck routes shall be cleaned and maintained daily.
- L.** The entire excavated area and equipment storage area shall be completely enclosed with a six (6') foot fence before any excavation begins and shall be maintained.
- M.** The hours of operation shall limited to:

Monday through Friday	7:00 a.m. – 7:00 p.m.
Saturday	9:00 a.m. – 3:00 p.m.
- N.** In addition to any bonds required under the State of Ohio Surface Mine Law (ORC Chapter 1514), a bond of two-thousand dollars (\$2,000) per site acre shall be filed with the Jerusalem Township Clerk to guarantee the satisfactory development and completion of any lake or pit. The entire project shall be bonded at once, and not bonded one acre at a time. All bonds shall be obtained prior to the start of any earthwork. Bonds shall be released by the Board of Township Trustees following fulfillment of all conditions of the Special Use permit.

1605 MORE THAN ONE PRINCIPAL BUILDING

No more than one (1) principal building may be located on a single lot, except when the following uses are permitted in the zoning district:

- | | |
|--|-------------------------------|
| Assisted living facility | Multi-family dwellings |
| Church or place of worship | Nursing home |
| Greenhouses | Public use |
| Hospital | School |
| Manufactured home/mobile home
(in a manufactured home park) | Self-service storage facility |
| Manufacturing | Storage facility |
| | Warehousing |

1606 NOISE

No person shall operate or use any machine, equipment or mechanical device on a lot except for agricultural purposes so as to create any noise which would cause the noise level, measured at the lot line of the lot affected by the noise emission, to exceed the applicable fixed noise level set forth in this section. If the measurement location is on a boundary between two zoning districts, the lower noise level shall apply.

Noise limits shall not exceed the following:

1. Zoning District	Time Period	Sound Level (dbA)
OS/P, A/R, R	10:00 p.m. – 7:00 a.m.	55
	7:00 a.m. – 10:00 p.m.	60
C-1, C-2, R-C	10:00 p.m. – 7:00 a.m.	65
	7:00 a.m. – 10:00 p.m.	70
M-1	Any time	70

2. Provisions of Section 1506(1.) shall not be applicable to any emergency signaling devices required by law; nor to any standby equipment operated only in emergency situations, provided that such standby equipment shall not emit noise at a level in excess of 75 dbA when measured at the lot line of the lot on which it is located.

1607 PONDS

1607.01 General Requirements

- A. Ponds shall not be permitted in any Zoning District on parcels less than two (2) acres.
- B. Prior to the issuance of a Zoning Certificate for a pond, and pursuant to Section 23 – Enforcement, of this Resolution, a waiver must first be obtained from the Toledo-Lucas County Regional Health District for any lot with on-site sewage or water system. The waiver including a site plan showing the pond location and other required information must first be reviewed and approved by the Jerusalem Township Zoning Inspector.

- C. Pond construction shall be completed within one (1) year from the date of the issuance of a Zoning Certificate.
- D. Approval shall be obtained from the Lucas County Building Regulations Department or the Lucas County Engineer prior to obtaining Township pond permit. A fill permit may be required for ponds constructed in a flood zone A area.
- E. Ponds shall conform to current Lucas County Soil and Water Conservation District specifications and guidelines.

1607.02 Area and Design Requirements

- A. Minimum pond surface area shall be one fourth (1/4) acre. Ponds may not exceed one half (1/2) acre except for parcels greater than five (5) acres in which ponds may not exceed one (1) acre maximum.
- B. The side slope of a pond shall be horizontal to vertical at a ratio of 3:1 except where a beach is desired. This ratio shall be maintained to a minimum depth of seventeen (17') feet. Where a beach is desired, from the shoreline away from the water, the beach grade shall be no greater than 4:1, with an overall minimum average pond depth of not less than nine (9') feet.
- C. To prevent adverse drainage effects on adjoining properties, a drainage system shall be installed to accommodate overflows and surface drainage from pond development; this system shall be diverted to a suitable outlet or drainage ditch.
- D. Ponds shall be graded not to exceed four (4) feet in height so it will not obstruct an adjoining property owner's view. Excess dirt shall be redistributed on the parcel.
- E. If a pond is deemed to pose a safety hazard because of the density of the development in the vicinity of the parcel, or the use of the parcel, the Zoning Inspector may require a minimum forty-two (42") inch fence be installed around the pond or the entire yard.
- F. All excavated material shall remain on the same parcel as the pond.
- G. The refilling of an area which has been excavated for the development of a pond shall be considered waste disposal and shall meet the requirements as set forth by the Lucas County Board of Health for solid waste disposal under 3734.05 O.R.C.

1607.03 Setback Requirements

- A. A pond shall be set back one hundred (100') feet minimum from any public road right-of-way.

- B. Ponds shall have a side and rear yard setback of not less than forty (40') feet.
- C. Ponds shall be located away from septic tanks, water wells and leach fields in accordance with Health Department standards.

1608 CAUSES OF BLIGHT OR BLIGHTING FACTORS

It is hereby determined that the following uses, structures and activities are causes of blight or blighting factors which, if allowed to exist, will tend to result in blighted and undesirable neighborhoods. No person, firm or corporation of any kind shall maintain or permit to be maintained any of these causes of blight or blighting factors upon any premises in Jerusalem Township owned, leased, rented or occupied by such person, firm or corporation.

- A. The storage upon any premises of any junk automobile, except in a completely enclosed building is prohibited. For the purpose of this Resolution the term "junk automobile" prima facia shall include any motor vehicle or watercraft which is not licensed for use upon the highways or waterways of the State of Ohio for a period in excess of fourteen (14) days.
- B. The outdoor storage upon any premises of building materials unless a zoning permit has been issued by the Township and a building permit issued by the Lucas County Department of Building Regulations not more than one (1) year previously for construction upon said premises, and said materials are intended for use in connection with such construction. Building materials shall include but shall not be limited to lumber, bricks, concrete or cinder blocks, plumbing materials, electrical wiring or equipment, heating ducts or equipment, shingles, mortar, concrete or cement, nails, screws, or any other materials used in constructing any structure. Provided, that outdoor storage of building materials which is not in violation of applicable zoning or safety regulations is permitted if said materials are kept out of view of the public and abutting premises. Provided further, that all construction debris shall be removed from any premises within thirty (30) days after occupancy thereof.
- C. The storage or accumulation of junk, trash, rubbish or refuse of any kind, except domestic refuse stored in such a manner as not to create a nuisance for a period not to exceed thirty (30) days. The term "junk" shall include parts of machinery or motor vehicles, unused stoves or other appliances stored in the open, remnants of wood metal or any other materials or other castoff materials of any kind whether or not same could be put to any reasonable use.
- D. The existence of any vacant dwelling, garage, or other out-building unless the same is kept securely locked, windows kept glassed or neatly boarded up, and otherwise protected to prevent entrance thereto by vandals.
- E. In any area the existence of any structure or part of structure which because of fire, wind or other natural disaster, or physical deterioration is no longer habitable as a dwelling, nor useful for any other purpose for which it may have been intended.

- F. In any area the existence of any partially completed structure, unless such structure is in the course of construction in accordance with a valid and subsisting zoning permit issued by the Township and a building permit issued by the Lucas County Department of Building Regulation and unless exterior construction is completed within one (1) year after issuance thereof.
- G. Shipping Containers/Storage Containers shall not be allowed for a period of time longer than thirty days in all districts. (Rev 12-20-17, Z28-C143)

No lot owner shall permit vegetation, garbage, refuse, or debris to exist on any lot and the Board of Township Trustees may determine and find from all circumstances that the existence of such vegetation, garbage, refuse, and debris to be a "nuisance" and that such nuisance causes injury to the property of another, endangers life and health, is offensive to the senses, violates laws of decency or obstructs reasonable and comfortable use of one's property. No land or building in any district shall be used or occupied in any manner which produces dangerous, injurious, noxious or otherwise objectionable elements or conditions which could adversely affect the adjacent land or pose a threat to the public health, welfare or safety of persons at the site or external to it.

1609 SATELLITE DISH ANTENNAS

Any satellite dish antenna that is independently supported in an "A" or "R" district shall be located toward the rear of the lot, shall be at least ten (10') feet from any main building, shall have rear and side property line setbacks equal to or greater than the height of the proposed structure, and, in the case of a corner lot, shall not project beyond the front yard required or existing on the adjacent lot. Where a satellite dish antenna is proposed to be independently supported, it shall not exceed fifteen (15') feet in height. Where a satellite dish antenna is proposed to be mounted on the roof of a building, it shall not extend more than fifteen (15') feet above the highest point of the roof of the building which it serves. In accordance with the Telecommunications Act of 1996, satellite dish antennas with a diameter of one (1) meter (39.37 inches) or less when located in an "A/R" or "R" District are exempt from the provisions of the Resolution.

Satellite dish antennas with a diameter in excess of one (1) meter (39.37 inches) are permitted in "A/R" or "R" Districts provided:

1. The satellite dish antenna shall be located toward the rear of the lot, at least ten (10') feet away from the main building, and setback from the rear and side property line a minimum of ten (10') feet.
2. Where a satellite dish antenna is proposed to be independently supported, it shall not exceed fifteen (15') feet above surrounding grade.
3. Where a satellite dish antenna is proposed to be attached to a roof of a building, the maximum height shall not exceed fifteen (15') feet above the highest point of the roof it is located on.

In accordance with the Telecommunications Act of 1996, satellite dish antennas with a diameter of two (2) meters (78.74 inches) or less when located in a "C" or "M" District are exempt from the provisions of this Resolution. Satellite dish antennas with a diameter in excess of two (2) meters (78.74 inches) are permitted in "C" and "M" Districts provided:

1. The satellite dish antenna shall be located toward the rear of the lot, at least ten (10') feet away from the main building, and setback from the rear and side property line, a minimum of ten (10') feet.
2. Where a satellite dish antenna is proposed to be independently supported, it shall not exceed fifteen (15') feet above surrounding grade.
3. Where a satellite dish antenna is proposed to be attached to a roof of a building, the maximum height shall not exceed fifteen (15') feet above the highest point of the roof it is located on.

1610 COMMERCIAL FISHING OPERATIONS

- A. The treatment, spreading and drying of commercial fishing nets shall be permitted only on parcels of two (2) acres or greater.
- B. Spreading of nets shall be no closer than fifty (50') feet of any lot line.
- C. All other operations including the loading, and unloading of nets, treatment of the nets shall not be permitted within one hundred fifty (150') feet of a residential dwelling.
- D. The treatment, spreading and drying of commercial fishing nets are exempt from Site Plan Review requirements.
- E. Proof of possessing a current commercial fishing license shall be provided to the Township's Zoning Inspector if requested.

1611 BUILDING AND GRADING COMPLETION

The finished exterior appearance of any building (including siding, masonry veneer, or other wall material, permanent roofing, trim, windows and doors) all being pre-finished, requiring no finish or having one (1) prime coat of paint, if required, shall be completed within eighteen (18) months from the issuance date of the Zoning Certificate.

Fill materials, rubble and earth intended for use on the premises shall be distributed and leveled to approximate finish grades within eighteen (18) months from the issuance date of the Zoning Certificate. Excess earth, construction rubble and excessive construction materials shall be removed from the premises, or stored within a completely enclosed building within eighteen (18) months from issuance of the Zoning Certificate.

1612 SEXUALLY ORIENTED BUSINESS

Because research has shown that sexually oriented business activities can cause or contribute significantly to the deterioration of residential neighborhoods, can impair the character and quality of such neighborhoods and the housing located therein, and can inhibit the proper maintenance and growth of such neighborhoods, limiting or reducing the availability of quality, affordable housing for area residents, and reducing the value of property in such areas, sexually oriented businesses shall only be permitted as follows:

Sexually oriented businesses are permitted uses in the C-2 zoning district provided the proposed locations of such uses are more than five hundred (500') feet from the following uses:

1. Any residential or agricultural zoned district, church, synagogue, permanently established place of worship, school, library, or public playground, or park.
2. Any other recreational facility, sports field or amusement park regularly attended by persons under eighteen (18) years of age.
3. Any other sexually oriented business or within a radius of one thousand (1,000') feet of any two sexually oriented businesses.
4. The measure of distance for purpose of this subsection shall be from the property line of the sexually oriented business use to the property line of the sensitive use along the shortest possible course, regardless of any customary or common route or path.
5. Approval of sexually oriented business.

The Zoning Inspector shall only consider the standard specified in this Zoning Resolution in determining whether to approve a sexually oriented business application for a zoning certificate. The determination shall be made without a public hearing being held and must be made within ten (10) days of the receipt of a complete application for a zoning certificate. No person, other than an applicant who has been denied a zoning certificate, may appeal the decision of the Township Inspector on an application for a zoning certificate for a sexually oriented business to the Board of Zoning Appeals. Any appeal to the Zoning Board of Appeals must be heard and determined within thirty (30) days of the filing of the Notice of Appeal. Further appeal shall be to a court of competent jurisdiction as provided by law.

1613 TELECOMMUNICATION TOWERS

Pursuant to the Telecommunications Act of 1996 and the ORC Section 519.211, and the Township Trustees being duly notified of a person's intent to construct a Telecommunication Tower in an area zoned "A/R", "R-1" or "R-3" District, this section sets forth standards to consider when reviewing the special use permit request. These minimum standards include:

1. The applicant must provide proof that the proposal to construct a tower or attach equipment to an existing structure has been approved by all other agencies and governmental entities with jurisdiction (i.e. Federal Communication Commission, Federal Aviation Administration, Ohio Department of Transportation).

2. The applicant shall provide proof of notification to adjacent property owners as required by ORC 519.211.
3. The applicant must demonstrate at the time of application that no technically suitable and feasible site is available in a non-residential district and that the site is located in the least restrictive district that includes a technically suitable and feasible site.
4. The tower and all accessory structures shall be located on a lot so that the distance from the base of the tower to any property line or supporting structure of another tower to any historically or architecturally significant building is a minimum of one hundred (100%) percent of the proposed tower height. No variance shall be granted from this minimum setback requirement.
5. The total height of the tower including any attached equipment or accessories such as antennas, etc. shall not exceed seventy-five (75') feet in height.
6. Towers less than seventy-five (75') feet in height that cannot satisfy this one hundred (100%) percent setback requirement may be approved, provided that the applicant present a certification from a registered engineer from the State of Ohio that the tower will withstand winds of one hundred (100) miles per hour.
7. Any and all base station equipment, accessory structures, buildings, etc. used in conjunction with the tower shall be screened with fencing, masonry, shrubbery or other screening materials.
8. The applicant shall notify the Zoning Inspector within thirty (30) days of ceasing operations at the site and shall remove all structures within sixty (60) days of ceasing operations.
9. No advertising or illumination other than that required by law may be located on the structure or on the required screening.
10. An inspection report prepared by a qualified engineer licensed by the State of Ohio shall be submitted to the Zoning Office every five (5) years which details the structural integrity of all towers and support structures on the property. The results of such inspections shall be provided to the Lucas County Building Regulations Department and Township Zoning Inspector. Based upon results of an inspection, the Township Trustees may require repair or removal of a communication tower. Any and all necessary repairs to the tower and/or support structures shall be made within a seven (7) day period or the tower and/or structures shall be removed. The tower owner (applicant) is responsible to cover the cost of all inspections, repair and/or removal.
11. The unstaffed storage building and/or unit that houses transmitting equipment is considered an accessory use and/or structure. Setbacks for accessory uses/structures will comply with distances in the zoned district of the tower location. These facilities may not include offices, long-term vehicle storage, other outdoor storage, or broadcast studios except for emergency purposes, or other uses that are needed to send or receive transmissions.

12. A six (6') foot safety fence with a locked gate surrounding the tower is required. If high voltage is necessary, signs must be posted every twenty (20') feet along the fence saying, "Danger – High Voltage". The operator must also post "No Trespassing" signs.
13. The applicant must demonstrate that "co-location" of the telecommunication tower with other telecommunication towers or facilities in the vicinity was considered. Co-location shall be encouraged wherever feasible.

1614 SUPPLEMENTAL YARD REGULATIONS

In addition to all yard regulations specified in each Zoning District, the following provisions shall be required as indicated:

A. Setback requirements for Corner Lots

On a corner lot, the principal building and any accessory structures shall be the same setback distance from all right-of-way lines as is required for the front yard setback in the district in which the structures are located.

B. Visibility at Intersections

On a corner lot in any Zoning District, nothing shall be located, planted or allowed to grow in such a manner as to impede, or restrict vision, between a height of two and one-half (2 ½ ') feet and ten (10') feet above the center-line grades of the intersecting streets in the area bounded by the right-of-way lines of such corner lot, and a straight line joining points along each street's right-of-way lines, which points are located fifty (50') feet from the point of intersection of the right-of-way lines at the corner.

C. Additional Yard Requirements For Buffering Purposes

To secure a desirable transition between land zoned for residential purposes and other zoning districts, larger yard setbacks shall be provided on the lot that is not zoned for residential purposes. The additional setback shall be along the lot line(s) that abut land zoned for residential purposes. When property that is zoned C-1, C-2, R-C, or M-1 abuts residentially zoned property, the yard requirements for that yard adjacent to the residentially zoned property, shall be increased two times the usual required setback, up to a maximum setback of seventy-five (75') feet. No off-street parking spaces, driveways, aisles, entrances, exits, circulation and maneuvering areas, or internal lanes shall be placed within this required yard.

1615 WATER FRONT LOTS

Lots having frontage along Lake Erie or its main channels and having frontage along a road or alley shall provide a front yard setback along the waterway. All other minimum yard requirements pursuant to this Resolution shall apply in accordance with this yard orientation.

1616 MAJOR ROADWAY SETBACK REQUIREMENTS

On lots abutting the following roads, no building or structure shall hereafter be constructed, enlarged, or reconstructed to extend nearer to the centerline of the right-of-way than seventy-five (75') feet:

Brown Road	Howard Road	Seaman Road
Cedar Point Road	Lyon Road	Teachout Road
Corduroy Road	North Curtice Road	Veller Road
Cousino Road	Rachel Road	Yondota Road
Decant Road		

***See Section 1406.1 for Jerusalem Road (SR2)**

1617 SWIMMING POOLS

Outdoor swimming pools are permitted as an accessory use and are regulated as follows:

1617.01 Residential Swimming Pool

Private swimming pools are permitted as an accessory use in any Zoning District provided the following conditions are met:

- A. The pool shall be used solely for occupants of the principal use of the lot on which the pool is located.
- B. The pool shall not be located, including accessory structures adjacent thereto, closer than ten (10') feet to any lot line of the property on which located, and shall be located behind the principle building.
- C. The swimming pool area shall be fenced or walled not less than four (4') feet in height, and the fence or wall shall be maintained. A swimming pool that is at least four (4') feet above grade on all sides, shall be secured with a lockable ladder and no fencing shall be required.

1617.02 Community or Club Swimming Pool

Community or Club swimming pools shall comply with the following conditions and requirements:

- A. A community or club swimming pool shall be any pool constructed by an association of property owners, or by a private club for use and enjoyment by members of the association or club and their families. Community and club swimming pools are permitted as a Special Use in any Residential or Commercial District.
- B. The pool and other accessory uses including decks and patios, shall setback not less than fifty (50') feet from any lot line.
- C. The swimming pool area shall have a perimeter fence or wall of not less than six (6') feet in height, and the fence or wall shall be maintained.

- D. When the pool is filled with water, adequate security lighting shall be provided and the pool area shall be locked.

1618 TEMPORARY BUILDINGS AND USES

- A. Temporary buildings, construction trailers, equipment and materials used in conjunction with construction work may be permitted only on the lot on which construction is occurring and only during the period construction work is in progress. Such temporary facilities shall be removed upon completion of the construction work.
- B. Real estate sales offices, which shall contain no residence, shall be permitted within any district for any new subdivision for a period of one (1) year beginning on the date the Final Plat is approved. Extensions of such use may be granted by the Board of Zoning Appeals. Such offices shall be removed upon the completion of the sales of the subdivision lots, or upon the expiration or extension of the Zoning Certificate, whichever occurs first.
- C. A Zoning Certificate may be issued by the Zoning Inspector for outside or seasonal sales within any commercial district. All goods located outside must be within four (4') feet of the principal building and not create a traffic, fire or pedestrian hazard. Temporary structures used for seasonal or outside sales may be permitted for one (1) continuous thirty (30) day period each calendar year. The temporary structure shall not create a traffic, fire or pedestrian hazard and all goods shall be located within the temporary structure.
- D. On-site construction debris shall be stored in an enclosed container so that debris is not spread to any neighboring properties or streets. Any materials and/or debris cleared from the building site shall be disposed of properly, pursuant to applicable regulations.

1619 YARD/GARAGE SALE

Any individual or family may conduct no more than two (2) yard or garage sales within any consecutive twelve (12) month period not to exceed five (5) consecutive days. Items displayed for sale shall not encroach into the right-of-way at any time.

1620 MOTOR VEHICLE SALVAGE YARDS

1620.01 Submission Requirements

- A. The applicant shall provide a complete and accurate legal description of the entire site.
- B. A site plan meeting all provisions of Section 1802 shall be submitted. The plan shall also indicate the storage areas, driveways, fencing, and landscape material.

1620.02 Storage

- A. Motor vehicle wrecking yards shall maintain a list of vehicles in stock and submit this list to the Township upon request.

- B. All loading and unloading of vehicles/parts and/or temporary storage of these items shall occur within the salvage yard behind the required fencing and out of view from the public.

1620.03 Licensing

All motor vehicle salvage yards shall be licensed as required by ORC 4737.

1620.04 Hours of Operation

Hours of operation shall be no earlier than 8:00 a.m. nor later than 6:00 p.m., Monday through Saturday.

1620.05 Fencing and Screening

Any area used as a motor vehicle salvage yard or junk yard shall be effectively screened on all sides by means of walls, fences and plantings. Walls or fences shall be a minimum of eight (8') feet in height and a maximum of ten (10') feet in height with no advertising thereon. Storage of materials shall not exceed this height. A strip of land not less than fifteen (15') feet in width on the perimeter of the yard shall be planted and maintained with evergreen hedges or other plant material with year round foliage. The plant material shall be equal to or greater than the height of the fence or wall at the time of planting.

1620.06 Yard Requirements

- A. Front Yard: There shall be a front yard of not less than fifty (50') feet, but where such a yard is opposite an A/R District or "R" District, it shall be a minimum of one hundred (100') feet and the first twenty-five (25') feet thereof shall be used only for landscaping purposes.
- B. Side Yard: There shall be side yard of not less than twenty-five (25') feet, but where abutting an "A/R: District or "R" District, it shall be a minimum of fifty (50') feet. Storage of materials and parking of vehicles is prohibited in a side yard.
- C. Rear Yard: There shall be a rear yard of not less than fifty (50') feet, but where such a yard is abutting an "A/R" District or "R" District, it shall be a minimum of one hundred (100') feet.

1620.07 Pavement

All roadways internal to the site shall be paved or maintained to minimize dust.

1620.08 Existing Non-conforming Uses

Special uses for those motor salvage yards that were lawfully established prior to the adoption of zoning may be granted. The purpose of the Special Use shall be to permit the motor salvage operator(s) to construct new or additional storage buildings. An expansion of an existing non-conforming motor vehicle salvage yard onto additional ground or area with a Special Use is strictly prohibited.

1621 TREATMENT OF SEWAGE

- A. Sewage plants, package treatment plants, or central treatment plants shall be fully housed in conformity with the development of the surrounding area. Prior to issuance of zoning certificate, plans must be submitted to Zoning Commission for approval.
- B. The dumping and/or spreading of sewage sludge, industrial sludge, and any by-product of the treatment of sewage or industrial waste is prohibited in all Districts within the Township, except "A/R" as regulated by Ohio EPA.

1622 PRIVATE TENNIS COURTS

A private tennis court shall be allowed in any District as an accessory use, and provided the following conditions and requirements are complied with:

- A. A site plan of the court location shall be submitted to the Zoning Inspector, together with approval of any public utility companies affected by any right-of-way or easement encroachments.
- B. The tennis court area shall not exceed seven thousand two hundred (7,200) sq. ft. in area (60 ft. by 120 ft.)
- C. The tennis court is intended and is to be used solely for the enjoyment of the occupants of the principal use of the property on which it is located.
- D. The tennis court may not be located, including any walks or paved areas, closer than twenty (20') feet to any property line of the property on which it is located.
- E. If a fence encloses the tennis court, the fence shall not exceed ten (10') feet in height and shall be maintained in good condition and free of all advertising or other signs
- F. Any and all lighting for a tennis court shall not project onto any adjacent property.
- G. The site plan shall indicate surface drainage flow directions. Overland flow to abutting properties shall not be permitted.
- H. No tennis courts shall be located over any septic fields or within any public right-of-way.

1623 SELF STORAGE FACILITIES

General Requirements:

- A. Self storage facilities shall be limited to rental of storage units, pickup and deposit of storage.
- B. Radioactive material, explosives and flammable or hazardous chemicals shall be prohibited from storage. This prohibition shall be included in the lease agreement of storage units. A copy of the lease agreement shall be filed with the Zoning Inspector or as a condition of the permit.

Specific Requirements:

- A. Lot Area: Minimum lot area shall be two (2) acres.
- B. Setback:
 - 1) Front Yard – fifty (50') feet
 - 2) Side or Rear Yard – twenty-five (25') when abutting or opposite an "A/R" or "R" District and fifteen (15') feet when opposite or abutting a "C" or "M" District.
- C. Height: Height of structures shall be equal to the average height of structures on properties abutting or opposite to self storage facilities. Where no adjacent structures exist, the maximum height shall be fifteen (15') feet to highest point of building.
- D. Lighting: Lighting shall be provided to illuminate facility entrances, driveways, parking areas and storage entrance areas and so arranged to reflect light away from adjoining residential property or any public way.
- E. Pavement: All roadways and parking areas shall be paved with concrete, asphalt or bituminous pavement.
- F. No door openings for any storage unit shall be constructed facing any residentially zoned property.
- G. Fencing, walls or landscaping/plant screening shall be required around the perimeter of the facility. Where deemed appropriate by the Zoning Commission, setbacks may be waived and a unit wall approved in lieu of a fence or landscaping as part of the site plan review process.
- H. Special Requirements: Where within five hundred (500') feet of a residence:
 - 1) Fencing or walls shall consist of decorative wood or stone, decorative concrete block or similar materials compatible with surrounding residential dwellings.
 - 2) Hours of operation shall be no earlier than 7:00 a.m. nor later than 8:00 p.m. daily.
- I. One (1) on-site dwelling unit to be used for a manager/security personnel is permitted.

1624

HOME OCCUPATIONS

General Requirements:

- A. In all A/R and R-1 Districts, a home occupation may include the use of an accessory building as a place for operation of the home occupation or for purposes of storage of equipment. The accessory building shall not exceed one (1%) percent of the lot area or two thousand (2,000) sq. ft. in area maximum, whichever is less.

- B. In a R-3 District a home occupation shall be confined to the dwelling and shall comply with part (D) of this Section.
- C. No more than one (1) person other than members of the family residing on the premises shall be engaged in such occupation.
- D. The use of the dwelling unit for the home occupation shall be clearly incidental and subordinate to its use for residential purposes by its occupants, and not more than twenty five (25%) percent of floor area of the dwelling unit shall be used in the conduct of the home occupation.
- E. There shall be no change in the outside appearance of the building or premises, no outside storage of materials incidental to the home occupation, and no other visible evidence of the conduct of such home occupation other than one (1) sign, not exceeding four (4) sq. ft. in area, non-illuminated.
- F. No traffic shall be generated by such home occupation in greater volume than would normally be expected in a residential neighborhood, and any need for parking generated by the conduct of such home occupation shall meet the off-street parking requirements as specified in this Resolution, and shall not be located in a required front yard.

1625 FILLING OF LAND

All filling of land with material from off-site in the Township shall require a Zoning Certificate. A grading plan shall be submitted to the Zoning Inspector along with a material list of the type of fill to be bought in prior to the issuance of the Zoning Certificate. Subject to the type of fill to be used, the Zoning Inspector may require the Toledo-Lucas County Regional Health Department's review and approval of the fill material. All material shall be graded within forty-five (45) days. Fill brought to a site to be used for a leach field system is exempt from this Section.

1626 OUTDOOR PARKING AND STORAGE OF VEHICLES WATERCRAFT AND TRAILERS

Storage of recreational vehicles, watercraft and/or utility trailers, are permitted in an "A/R" or "R" District when the following conditions and requirements are complied with:

- A. No such vehicles, watercraft or trailers shall be parked or stored in a front yard.
- B. Such vehicles, watercraft or trailers may be parked or stored in a rear yard, but not within ten (10') feet of any lot line.
- C. Such vehicles, watercraft or trailers parked or stored on a lot shall not have fixed connections to electricity, water, gas or sanitary sewer facilities, and at no time shall this equipment be used for living or housekeeping purposes.
- D. Only two (2) recreational vehicles, watercraft or trailers or a combination thereof, shall be parked or stored in an "A/R" or "R" District. No parking is allowed on parcels without a principal structure.

- E. Notwithstanding the provisions of this Section, such vehicles, watercraft or trailers may be parked anywhere on the premises for loading and unloading purposes, for a period of not more than seventy-two (72) hours. No parking is allowed on the right-of-way.
- F. Recreational vehicles, watercraft and/or utility trailers parked or stored on a vacant parcel shall be prohibited except where permitted as an accessory use (parking lot), to a commercial or industrial business.

1627 LAWN/TREE SERVICE

Any and all equipment and/or storage of material(s) used in conjunction with a lawn/tree service shall be suitably screened on all sides with fencing and/or landscape material.

1628 STORAGE YARD

Storage yards shall conform to the following requirements:

All areas used for storage shall be effectively screened on all sides by means of a wall or fence and plantings. Walls for fences shall be a minimum of six (6') feet in height with no advertising thereon. A strip of land not less than fifteen (15') feet in width shall be provided on the perimeter of the storage yard and shall be planted and maintained with evergreen hedges or other plant material with year round foliage. The plant material shall be equal to or greater than the height of the fence or wall at the time of planting.

1629 SMALL WIND TURBINE

A. General Requirements

1. Small wind turbines are a permitted use in the Agricultural/Residential A/R District on parcels three (3) acres or greater in size.
2. The small wind turbine shall service only one residence.

B. Specific Requirements

1. Height: The total height of the tower shall not exceed eighty (80') feet, which is measured from adjacent grade to the highest point of the rotor tip. The minimum distance between the ground and any protruding blades shall be fifteen (15') feet as measured at the lowest point of the arc of the blades.
2. Fall zone: The small wind turbine shall be a distance of at least 125% of height of the total structure from any property line, dwelling, or right-of-way.
3. Set-back: No part of the small wind turbine structure, including guy wire anchors, shall extend closer than ten (10') feet to the property line.
4. Lighting: The maximum lighting used on the structure is a low intensity red light regulated by the Federal Aviation Administration.
5. Electrical generator: The small wind turbine shall have a rated capacity of not more than 15kW.

6. Noise: Noise coming from the small wind turbine shall not exceed 60 dBA to the nearest property line. Documentation from the wind turbine manufacturer shall be provided to the Zoning Inspector stating the dBA's produced by their product.
7. Fencing: The supporting tower shall be enclosed with a six (6) foot high fence unless the base of the tower is not climbable for a distance of twelve (12') feet.
8. Base: All tower support bases shall be made of concrete or any other material approved by the Lucas County Building Regulations Department.
9. The applicant shall notify the Zoning Inspector if operations of the wind turbine cease and the wind turbine shall be removed within 60 days of ceasing operations.
10. The small wind turbine transmission lines shall be underground.
11. Prior to the installation of a small wind turbine, a Zoning Certificate shall be obtained. A site plan and all other pertinent information shall be submitted to the Zoning Inspector for review.

1630 MEDICAL MARIJUANA FACILITIES

The following standards apply to Medical Marijuana Facilities, as defined in Section 31 of this Resolution. All such facilities shall also comply with Ohio Revised Code Section 3796.

- A. Medical Marijuana Facilities shall not be located within 500 feet of any school (K-12), church, public park, public playground, public library, pre-school, child day care center, publically owned property, or other use established specifically for the activities of minors.
- B. Medical Marijuana Dispensaries may be allowed as a conditional use provided that the conditions below are complied with and other applicable conditions of Section 22 Site Plan Review.
 1. The hours of operation of a Dispensary shall be limited to 7 a.m. to 9 p.m., or other hours consistent with a Medical Marijuana Dispensary permit issued by the State of Ohio, as a condition of approval.

(Rev 12-20-17, Z28-C142)

SECTION 17

NON-CONFORMITY

1700 PURPOSE

Within the districts amended and established by this Resolution, or amendments hereafter adopted, certain lots, uses of land, structures, and their use in combination with the land which were existing and lawful prior to this amended Resolution or as may be amended would be prohibited, regulated, or restricted under the terms of this Resolution or future amendments. Non-conformities shall not be enlarged, expanded or extended, and shall not be used for adding or substituting other structures, buildings or uses that are prohibited in the same district.

1701 NON-CONFORMING LOTS OF RECORD

Any lot of record fifty (50') feet or more existing at the effective date of this Resolution in any A/R or R-1 District may be used for a single-family dwelling even though its area and width are less than the minimum requirements set forth herein. Each side yard shall be a minimum of five (5') feet. Where two adjacent lots of record with less than the required area and width are held by one owner, the lots shall be combined and used for one (1) main building. The zoning district front and rear yard setback shall be met. All requirements for well and septic systems if necessary shall meet the specifications of the Toledo-Lucas County Health Department.

1702 NON-CONFORMING USE OF LAND

The lawful use of land which use would not be permitted by the provisions of this Resolution may be continued so long as such use remains otherwise lawful, and provided:

- A. No such non-conforming use shall be enlarged or increased in its size, dimension, intensity and shall not be extended to occupy a greater area of land than such use occupied at the effective date of this Resolution.
- B. No such non-conforming use shall be moved in whole or in part to any area of the lot other than that occupied by such use at the effective date of this Resolution.
- C. If any such non-conforming use of land is discontinued or abandoned for more than two (2) consecutive years, any subsequent use of land shall conform to the requirements specified by this Resolution for the district in which such land is located.
- D. No new structures shall be located on a lot with a non-conforming use of land.
- E. All non-conforming uses shall comply with County and State Health Department regulations in regards to sanitary waste disposal facilities.
- F. A non-conforming use may be substituted with another similar non-conforming use provided no structural alterations are required and subject to approval by the Board of Zoning Appeals. A non-conforming mobile or modular home may not be substituted with another mobile or modular home.

1703 NON-CONFORMING BUILDINGS AND STRUCTURES

Where a lawful building or structure exists at the effective date of this Resolution that is not otherwise permitted pursuant to this Resolution due to building area, lot coverage, height, setbacks, yards, or location on the lot, such building or structure may be permitted so long as it remains otherwise lawful, subject to the following:

- A. In the event that any non-conforming building, structure, or mobile, manufactured or modular home is destroyed by any means to the extent or more than sixty (60%) percent of the cost of replacement of such structure, exclusive of foundation, it shall not be rebuilt, restored, or reoccupied for any use unless it conforms to all regulations of this Resolution and the following conditions:
 - 1. A Zoning Certificate for such restoration shall be first obtained within one (1) year of such damage or destruction;
 - 2. Such repair shall not cause a new or additional non-conformity and such repair shall not increase the size, dimension or intensity of non-conformity that existed prior to such damage or destruction.

1704 PRIOR ZONING APPROVALS

Any zoning or land use approval granted prior to the adoption of this amended Resolution shall remain in effect pursuant to the provisions of the Section and terms of such approval. Any changes to the approved zoning or site plan shall require re-submittal of the zoning or site plan request and shall meet all requirements of this amended Resolution.

1705 REPAIRS AND MAINTENANCE

On any non-conforming structure or portion thereof containing a non-conforming use, work may be done on ordinary maintenance repairs, or on repair or replacement of non-bearing walls, fixtures, wiring, or plumbing, provided the cubic content that existed when it became non-conforming shall not be increased. Nothing in this section shall be deemed to prevent the strengthening or restoring to a safe condition of any building or part thereof declared to be unsafe by any official charged with protecting the public safety, upon order of such official. Where appropriate, a Zoning Certificate for such activities shall be required.

SECTION 18

SIGNS AND OUTDOOR ADVERTISING

1800 PURPOSE

This section provides standards for the placement, display and use of signs. These standards are designed to enhance the aesthetic environment of the Township, improve pedestrian and traffic safety, and minimize possible adverse effects of signs on nearby public and private property.

1801 DEFINITIONS

Abandoned Sign: A sign or sign structure which no longer identifies or advertises a business, service, owner, product, or activity. Such sign and sign structure shall be removed within thirty (30) days of notice to the property owner by the Zoning Inspector.

Animated Sign: A sign or display manifesting either kinetic or illusionary motion occasioned by natural, manual, mechanical, electrical, or other means of power.

Area Identification Sign: A sign which identifies a subdivision or complex, whether residential, commercial, or industrial

Awning/Canopy Sign: A sign attached to an awning covering a doorway, window, or face of the building.

Banner: A temporary display including a sign on a flag, strip of lightweight material, paper, cloth, or fabric which is attached to a building, another sign, or any other structure.

Billboard: (See Off-Premise Sign)

Building Face Or Wall: All window and wall area of a building in one plane or elevation.

Changeable Copy Sign: A sign or portion thereof with characters, letters, or illustrations that can be changed or rearranged without altering the underlying face or the surface of the sign.

Clearance Of Sign: The smallest vertical distance between the grade of the adjacent street, highway, or street curb and the lowest point of any sign, including its framework extending over that grade.

Commercial Message: Any wording, logo, or other visual representation that directly or indirectly identifies, advertises, or calls attention to a business, product, service, or other commercial activity.

Construction Sign: A temporary sign identifying an architect, contractor, subcontractor, and/or material supplier participating in construction on the property on which the sign is located.

Copy: The graphic content of a sign surface in either permanent or removable letter, pictographic, symbolic (logo), or alphabetic form.

Directional Sign: An on-premise sign not exceeding four (4) square feet per face and the highest edge of which is no higher than three (3') feet above curb grade, that gives directions or instructions to facilitate traffic flow. Such signs shall not contain the business name or logo. Directional signs are not included in the sign area calculations; however, a sign permit is required.

Double-Faced Sign: A sign with two (2) faces.

Embellishment The decorative or ornamental structure or frame that contains a sign. Embellishments are not included in the square footage of the sign's area calculation, shall not exceed twenty-five (25%) percent of the single face area and shall not exceed the maximum permitted height.

Exempted Signs: Exempted from sign permit requirements.

Façade: The entire building front including the parapet.

Frontage, Building: The length of the outside building wall along a right-of-way.

Future Development Sign: A temporary sign indicating the future construction or development of a building or area but not fitting under the definition of "construction sign".

Height: The vertical distance measured from the highest point of the sign, excluding decorative embellishments, to the grade of the adjacent street or the surface grade beneath the sign, whichever is less.

Low Profile Sign: A sign placed directly on the ground with maximum height not to exceed five (5') feet measured from adjacent ground surface.

Message: The wording or copy on a sign.

Non-conforming Sign: A sign which was placed on the lot legally, but which does not comply with subsequently enacted sign regulations.

Off-Premise Sign (also Billboard): A sign structure advertising an establishment, merchandise, service, or entertainment, which is not sold, produced, manufactured, or furnished on the lot on which said sign is located.

Pennant: Any lightweight plastic, fabric, or any other material, whether or not containing a message of any kind, suspended from a rope, wire, or string, usually in series, designed to move in the wind.

Pole Sign: Any sign supported by upright structure(s) or support(s) that are anchored in the ground and that are independent from any building or other structure on the lot.

Portable Sign: Any sign not permanently attached to the ground or other permanent structure, or a sign designed to be transported including, but not limited to: signs designed to be transported by wheels; "A" or "T" frame signs; menu and sandwich board signs; umbrellas used for advertising; and signs attached to or painted on vehicles parked and visible from the public right-of-way, unless said vehicle is used regularly in the usual and customary operations of the business and other than a structure on which to place a sign.

Political Sign: A temporary sign used in connection with a local, state, or national election.

Projecting Sign: A sign, other than a flat wall sign, which is attached to and projects from a building wall or other structure not specifically designed to support the sign.

Public Service Information Sign: Any sign primarily to display items of general interest to the community such as time, temperature, and date. Public service information signs may be permitted in Commercial and Industrial Districts only, and are not included in the sign area allowed for the lot.

Real Estate Sign: A temporary sign advertising the real estate upon which the sign is located as being for rent, lease, or sale.

Roof Sign: Any sign erected and constructed wholly on and over the roof of a building, supported by the roof structure.

Sign: Any device, fixture, placard, or structure that uses any color, form, graphic, illumination, symbol, or writing to advertise, announce, or identify a person, entity, product, service, establishment, activity or sale which communicate information of any kind.

Sign Area: The area of the largest single face of the sign where the copy is placed, but excluding the necessary supports and frame on which the sign may be placed.

Sign Face: The sign area of which copy is placed.

Sign Structure: Any structure which supports, has supported, or is capable of supporting a sign, including decorative cover.

Temporary Sign: Any portable sign, flag, pennant, banner, balloon, garage sale sign, search light, twirling light, sandwich board, inflatable figures, or public election and candidate sign that is used temporarily or is not permanently mounted.

Wall Sign: A sign attached to or placed against a wall of a building, with the sign face parallel to the building wall and extending away from the building wall not more than one (1') foot therefrom, which copy advertises the use carried on within such building.

Window Sign: Any sign, pictures, symbol, or combination thereof, designed to communicate information about an activity, business, commodity, event, sale, or service, that is placed inside a window.

1802 GENERAL PROVISIONS

- A.** Unless otherwise provided by this Resolution, all new signs shall require a Zoning Certificate. Application for a Zoning Certificate shall be made to the Zoning Inspector. Payment of fees shall be in accordance with the fee schedule. No Zoning Certificate is required for the maintenance of a sign or for a change of copy on painted, printed, or changeable copy signs, so long as the sign area or structure is not modified in any way for the existing business.
- B.** Each application for a sign permit shall include a drawing of the proposed sign showing the following information:

1. Name and address of the owner of the sign.
 2. Street address or location of the property on which the sign is to be located, along with the name and address of the property owner.
 3. The type of sign or sign structure as defined in this Resolution.
 4. A site plan with dimensions showing the proposed location of the sign with measurements from grade and from all property lines along with the location of all existing signs and buildings on the same premises, and adjacent roadways.
 5. A drawing of the proposed sign showing the following specifications: dimensions, height, design, copy, illumination, and construction details (materials, structural supports, and electrical components) of the proposed sign.
 6. Computations showing total number and area of existing and proposed signs on the lot.
- C. No sign shall project into any right-of-way or obstruct traffic visibility at street or highway intersections.
- D. If a sign is installed, constructed, or maintained in violation of any of the terms of this Resolution, the Zoning Inspector shall notify the owner or lessee thereof to alter such sign so as to comply with this Resolution. Any owner, leasee, or sign contractor who installs a new sign without a Zoning Certificate shall be subject to three (3) times the normal fee schedule.
- E. All signs that do not presently conform to this Resolution shall be removed within five (5) years and six months from the effective date of this Resolution unless a variance was granted for the sign prior to the adoption of this amendment.

1803 PROHIBITED SIGNS

The following types of signs are prohibited in all districts:

- A. Abandoned signs.
- B. Animated signs.
No sign shall be permitted which is animated by means of flashing, blinking, or traveling lights or any other means not providing constant illumination. Public service information signs and changeable copy signs are not considered animated signs.
- C. Temporary and Portable Signs.
Flags, pennants, banners, search lights, twirling signs, sandwich board signs, balloons, or other inflatable figures, except for the opening of a new business or re-opening of a seasonal business in a commercial or industrial district for a total period not to exceed thirty (30) days per year, after first obtaining a Zoning Certificate.
- D. Flags other than those of any nation, state, or political subdivision.

- E. Any sign or other object attracting attention to a business which interferes with the safety of the traveling public.
- G. Roof Signs.

1804 EXEMPTIONS

The following signs do not require a Zoning Certificate:

- A. Any public notice or warning required by a valid and applicable federal, state, or local law or regulation.
- B. Any sign wholly inside a building.
- C. Non-illuminated real estate signs not exceeding six (6) square feet in sign area for A/R or R-1 zoned property and thirty-two (32) square feet in sign area for all other districts, which advertises the sale, rental, or lease of the premises upon which such sign is located.
- D. Non-illuminated real estate signs not exceeding thirty-two (32) square feet per face in sign area which advertise the sale or lease of a subdivision or undeveloped acreage of ten (10) acres or greater.
- E. Signs denoting the architect, engineer, developer, bank, title company or contractor when placed upon the lot under construction, and not exceeding thirty-two (32) square feet in sign area.
- F. Memorial signs or tablets, name of buildings and dates of construction, provided that such signs do not exceed two (2) square feet in sign area.
- G. Garage/yard sale signs, public election and candidate signs. These signs shall be removed no later than five (5) days after completion of the election, event or transaction.
- H. Address numbers for dwellings shall not exceed two (2) square feet in area and address numbers for commercial or industrial buildings shall not exceed six (6) square feet in area unless the address number is an integral component of a sign for which a Zoning Certificate is required by this Resolution.

1805 AGRICULTURAL, RESIDENTIAL, AND PUBLIC/OPEN SPACE DISTRICTS

Signs shall be permitted as follows:

- A. One (1) low-profile or one (1) wall sign shall be allowed for each lot which contains a main building. No commercial message shall be allowed on the sign, except for a commercial message drawing attention to an activity legally offered on the premises. Low-profile signs in A/R and R Districts shall not exceed forty-two (42") inches in height from adjacent street grade and 24 square feet in area per face with maximum of two (2) faces. Wall signs in an A/R and R District shall not exceed twelve (12) square feet in area.

Signs for home occupations shall be non-illuminated and not exceed two (2) square feet in area.

- B.** Signs for a church, school, or other public or semi-public building shall not exceed thirty-two (32) square feet per face in area.
- C.** At any entrance to a residential subdivision or multi-family development there may be not more than two (2) signs identifying such subdivision or development and shall be setback from the right-of-way a minimum distance of ten (10) feet. The total sign area of a single sign located at a single entrance shall not exceed thirty-two (32) square feet, shall not exceed forty-two (42") inches in height, and shall contain only the name of the subdivision or development. Any subdivision entrance/identification sign proposed to be located within the center of a boulevard entrance shall be located in a manner so as not to create a traffic hazard from the standpoint of adequate sight distances.
- D.** All signs except traffic directional signs and real estate signs shall be located a minimum distance of twenty (20') feet from the right-of-way line and not less than twenty-five (25') feet from any adjacent lot line.

1806 COMMERCIAL AND INDUSTRIAL DISTRICTS

A. Maximum Total Square Footage.

The total square footage of all permanent sign faces shall be limited to a maximum of two (2) square feet for every lineal foot of street frontage not to exceed the maximum allowed in Table 17-1. One (1) of each sign type listed in Table 1, except as listed in 1707.13, shall be permitted per lot:

TABLE 1706 – 1

ZONING DISTRICT	TYPE OF SIGN PERMITTED	MAX. SIZE OF POLE SIGN (sq. ft.)	MAX. SIZE OF WALL SIGN (sq. ft.)	MAX. SIZE OF LOW PROFILE SIGN (sq. ft.)	MAX. SIZE OF PROJECTING SIGN (sq. ft.)
C-1	Wall, Low profile, projecting, pole	60 per face	10% of wall area	60 per face	40 per face
C-2	Wall, low profile projecting, pole	100 per face	20% of wall area	100 per face	40 per face
R-C	Wall, low profile, Pole	100 per face	20% of wall area	100 per face	N/A
M-1	Wall, low profile	N/A	10% of wall area	50 per face	N/A

B. Exceptions to Table 17 – 1

1. Lots fronting on two (2) or more streets are allowed the permitted sign area for each street frontage, but sign area may not be accumulated and used on one (1) street in excess of that allowed for lots with only one (1) street frontage.
2. Lots fronting on two (2) or more streets are permitted multiple wall signs provided wall sign is facing a right-of-way and the combined square footage is within the wall sign size limit indicated.
3. Awning and canopy signs are treated as wall signs for the purpose of this table. The sign area for these signs is the copy area.
4. A low profile sign is not permitted when a pole sign is used.
5. A projecting sign is not permitted when a pole sign is used.

C. Height, Location and Vertical Clearance of Signs

The maximum height and minimum vertical clearance are measured from existing grade. The location is measured from the right-of-way line. All following dimensions are in feet and apply to pole signs in the Commercial, Recreational, and Industrial Districts, except as provided for:

Maximum Height	20*
Minimum Setback	20
Minimum Vertical Clearance	9*

***Does not apply to low profile signs**

1807 COMMON SIGNAGE PLANS FOR MULTIPLE USES

- A.** In lieu of the requirements elsewhere in this chapter, when a structure contains more than one (1) business establishment, or when the owners of two (2) or more contiguous lots voluntarily agree to develop common signage, a common signage plan may be submitted.
- B.** A common signage plan shall specify standards for consistency among all signs affected by the plan in regard to:
 1. Color scheme
 2. Lettering
 3. Lighting
 4. Location of signs
 5. Material and construction
 6. Sign Proportion/size
- C.** Common signage plans may not exceed the following limitations:

1. Maximum Sign Area: The total maximum aggregate area of all signs (pole, wall, low profile or projecting) shall not exceed either three (3) square feet of signage per lineal foot of street frontage, or five (5) percent of the ground floor of the principal building, or one thousand (1,000) square feet, whichever is less.
2. Maximum Number of Pole or Low Profile Signs: Pole or low profile signs are limited to one (1) for each three hundred (300) feet of frontage.

1808 OFF-PREMISE SIGNS

Off-premise signs are permitted in districts zoned for industry and business and lands used for agricultural purposes per ORC 519.20, subject to the following:

- A. Off-premise signs shall be limited to billboards and poster panels.
- B. Billboards and poster panels shall not exceed seventy-two (72) square feet per sign face.
- C. Height of billboard and poster panels shall not exceed fifteen (15') feet above grade.
- D. One (1) off-premise sign per parcel is permitted.
- E. Off-premise signs are not permitted on parcels with on-premise signs.
- F. Billboards and/or poster panels shall be set back at least as far as the required front yard depth for a principal use in that district. No sign or advertising structure shall be no closer than fifty (50') feet of a side or rear lot line.

SECTION 19

SITE PLAN REVIEW

1900 PURPOSE

Site plan review provides a procedure with specific standards for development proposals. Items to be considered include but are not limited to traffic & storm water management, preservation of existing natural features, adjacent land uses, general welfare and safety.

1901 APPLICATION

Site plan review and landscaping pursuant to this Section is required for all new construction including parking lots and other parking. Site plan review is also required for the alteration, modification, change of use, or an enlargement of an existing structure whereby the enlargement is greater than five thousand (5,000) square feet or whereby the enlargement is greater than fifty (50%) percent of the existing floor area. Single family and two-family dwellings and related accessory structures and buildings are exempt from the Site Plan Review procedure.

1902 REQUIREMENTS

An applicant shall file with the Zoning Inspector, the following documents along with the application fee.

1902.01 Basic Requirements

- A. A letter of submittal from the property owner or an agent authorized in writing by the property owner shall accompany the site plan that contains the applicant's phone number and mailing address.
- B. The site plan documents shall include a complete legal description of the property and a general location sketch showing nearby section lines and/or residential and major roadways.
- C. All site plans shall have a title – "Site Plan Review". The site plan shall indicate the scale of the drawing and shall use an engineer's scale. The site plan shall have the north arrow pointing either toward the top of the drawing or to the left side of the drawing. The location map and site plan orientation shall be the same.
- D. The following documents shall be filed: Fifteen (15) blueline or blackline prints of the site plan on paper no larger than 24" x 36". Detailed drawings other than the site plan need not be submitted for the purpose of site plan review.

1902.02 Site Plan Requirements

- A. The site plan shall show the zoning classification(s) and existing uses of the property and all abutting property; the approximate location of buildings and driveway locations opposite to, and adjacent to the property.

- B.** The site plan shall indicate the dimensions including area of the property, the dimensions of the existing and proposed buildings to be constructed, and any buildings to be removed or other alterations to occur on the property.
- C.** The site plan shall indicate the distance of existing and proposed structure(s) to all right-of-way lines and the distances of the structure(s) to the front, side and rear property lines.
- D.** The site plan shall indicate the name of all adjacent roadways and right-of-way and pavement widths measured from the centerline of the roadway.
- E.** The site plan shall indicate the locations, height, and material of all existing and proposed fencing and/or walls on the property.
- F.** The site plan shall show the location, height, lighting and dimensions of existing or proposed signs on the property.
- G.** The site plan shall indicate the width(s) and location(s) of existing or proposed sidewalks, if any, and drive approach aprons. The drive approach width(s) shall be indicated where the apron meets the roadway pavement and shall be dimensioned at the throat.
- H.** The site plan shall show any ditches, creeks, or other natural features that may affect the development of the property. Where appropriate, two-foot (2') contours and the 100-year high water elevation shall be shown on the site plan. Information on this requirement may be obtained from the Lucas County Engineer's Office.
- I.** The site plan shall show the existing and proposed method of storm water drainage and/or areas to be used for storm water detention.
- J.** The site plan shall show existing and proposed sanitary and storm sewers, water mains, and the location of fire hydrants if present. In the event these improvements are not proposed, the site plan shall indicate the location of proposed or existing wells and sewage systems both on-site and on abutting parcels.
- K.** The site plan shall indicate the location of existing or proposed off-street parking spaces and drive aisles with complete dimensions, the number and size of the proposed parking stalls including handicap spaces and the type of pavement composition of the parking area, such as asphalt or concrete, and if the off-street parking area is located next to an existing parking area or on another parcel, the method of circulation, if any, between the two areas.

- L. A site plan with a proposed drive-thru window operation shall indicate where the vehicle will be lined-up and how many vehicles can be stored at one time while waiting to use the order board and drive-thru window.
- M. Exterior building elevation(s) visible from all abutting streets and highways.

1903 APPROVAL PROCEDURE

- A. Site plans shall be filed with the Zoning Inspector. Site plans shall not be circulated for review and recommendation unless all required information is submitted and/or indicated on the site plan. On-site notices are available at the Township Zoning Office.
- B. The applicant must post and maintain one or more on-site notices as required. The applicant is responsible for removing the posted notices within ten (10) days after the decision of the Zoning Commission. No one except the applicant, agent or Zoning Inspector shall remove or tamper with any such notice during the time it is required to be posted and maintained.
- C. The Zoning Inspector shall transmit the site plan to appropriate governmental agencies for review, report and recommendation.
- D. Once all recommendations have been received, the Zoning Inspector shall transmit the site plan and recommendations to the Zoning Commission for review and approval or denial.
- E. As part of the site plan review, a bond, escrow, or other suitable guarantee to ensure the implementation of site improvements may be required by the Zoning Commission.
- F. Changes to the approved site plan may require resubmittal for review pursuant to this Section. The Zoning Inspector may administratively approve changes to the approved plan provided the change(s) in the plan do not:
 - 1. Result in an increase in the number of units;
 - 2. Encroach materially into the setback areas;
 - 3. Encroach into the parking areas so as to cause an alteration in the layout of the access drives or provisions for additional parking spaces;
 - 4. Create a large building mass either through an increase in its height, length, or width that would magnify its effect on the adjoining areas;
 - 5. Alter specific conditions approved by the Zoning Commission.

1904 EXPIRATION AND EXTENSION OF SITE PLAN APPROVAL

If construction of any phase of the approved site plan begins within two (2) years after approval is granted, the approval shall be valid until the development is completed. If no construction has begun within two (2) years after the approval is granted, the site plan shall be void. An extension of the time limit may be approved by the Zoning Commission.

SECTION 20

LANDSCAPING REQUIREMENTS

2000 PURPOSE

The landscaping requirement is to establish standards to enhance appearance and preserve native vegetation. To the greatest extent practical, development should preserve natural features. The use of native vegetation is encouraged and may be approved as part of the landscape review process.

2001 REQUIREMENTS

2001.01 General

Landscaping for all uses except single-family and two-family dwellings, shall be provided in the following areas;

- A. At the perimeter of sites to buffer, separate, and/or screen adjacent land uses;
- B. At the perimeter of parking lots to shade, separate, and/or screen the view of parked cars from adjacent streets and land uses;
- C. In the interior of parking lots to provide shade;
- D. Around the perimeter of buildings to enhance the appearance of structures;
- E. When barriers or fences are utilized, plant material shall be included;
- F. Required landscape areas shall not include any portion of the right-of-way;
- G. All loading areas shall be landscaped for screening purposes;
- H. Trash receptacles shall be screened on all sides and shall not be placed within any required setback areas.

2001.02 Specific

- A. A planting strip at least five (5') feet in width shall be located along the perimeter of a parking area but not within any right-of-way. Within this area, there shall be one (1) two and a half (2.5") inch caliper deciduous shade trees per fifty (50) linear feet of perimeter parking area. There shall also be a four (4') feet tall solid hedge of shrubs (evergreen or deciduous) to provide screening. An alternative arrangement of perimeter landscaping material such as mounding, fencing, or walls may be considered as part of the site plan review process.

- B.** Landscaping within parking areas is necessary not only to reduce the generation of heat and water runoff but to break up visually the expanse of paved areas. The use of shade trees in these landscape areas shall be required. Any open parking area (including loading areas) containing more than six thousand (6,000) square feet of area or fifteen (15) or more parking spaces shall provide the following interior landscaping in addition to the required perimeter screening:
1. An area equal to five percent (5%) of the total area devoted to parking spaces and aiseways shall be landscaped and permeable.
 2. For parking areas over thirty thousand (30,000) square feet in size, the required landscaping shall be designed to break up the visual expanse with landscape features such as boulevards, larger landscape islands, or areas of preserved on-site native vegetation. This landscaping requirement may also include storm water retention areas or drainage courses, if designed so as to provide an attractive natural asset to the site.
 3. All required landscape areas shall be protected by curbing or a suitable barrier to prevent vehicle encroachment.
 4. The required plant materials for the interior of parking areas shall be one deciduous tree for every three thousand (3,000) square feet of area. Where site distance or maneuvering conflicts exist, trees shall have a clear trunk of at least five (5') feet above the ground, and the remaining required landscape areas shall be planted with shrubs or ground cover not to exceed two feet in height.
 5. Foundation plantings are required for all exterior building walls, that are visible from a road. Foundation plantings shall be placed within five (5') feet of the building perimeter. Ten (10) shrubs shall be required for every one hundred (100') lineal feet of horizontal exterior building wall visible from the road, street, or highway. If foundation plantings are deemed not practical due to unique features of the site and/or building, an alternative plan may be considered as part of the site plan review process.

6. A landscape strip adjacent to the road right-of-way shall be provided along the full width of a lot, except when a front access drive is provided pursuant to Section 14 of the Resolution. The width of this landscape strip shall be not less than fifteen (15') feet measured from the right-of-way line. The landscape strip shall be unoccupied except for landscape material, steps, walks, terraces and driveways. Innovative treatments are encouraged in this area, but the design must not interfere with adequate sight distance. Within the landscape strip, at least one (1), two and one-half (2 ½") inch caliber deciduous or two (2), six (6') foot high evergreen trees, or a combination, shall be installed for each one hundred (100') feet of property frontage along with other appropriate landscape materials.
7. An irrigation system shall be installed in all required landscape areas unless drought resistant, native species are utilized.

2002 PLANT MATERIAL SPECIFICATIONS

The following sections include specifications for plant materials. Alternatives to these specified plant materials which demonstrate both the intent and requirements of this Resolution may be approved as part of a Site Plan:

- A. Deciduous Trees**
A minimum caliper of at least two and one-half (2 ½") inches measured twelve (12") inches above ground level at time of planting.
- B. Evergreen Trees**
A minimum of six (6') feet high and a minimum spread of three (3') feet at time of planting.
- C. Shrubs**
Shrubs shall be at least thirty (30") inches average height and twenty-four (24") inches width at the time of planting.
- D. Ground cover and Grass**
Ground cover shall be planted a minimum of eight inches on center and shall be planted in such a manner so as to present a finished appearance and seventy-five percent (75%) coverage after one complete growing season. If approved as part of a Site Plan, ground cover may also consist of rocks, pebbles, shredded bark, mulch, and other material. Grass shall be planted in species normally grown as permanent lawns.
- E. Prohibited Tree/Shrub Species**
The following tree and shrub species shall not be used unless already existing in the proposed landscape area:

Box Elder (Acer negundo) Walnut
Mulberry (Morus alba)
Willow (Salix babylonica)
Siberian Elm (Ulmus pumila)
Hickory (Carya sp.*)

European Alder-Buckthorn (*Rhamnus frangula*)
Common Buckthorn (*Rhamnus cathartica*)
Autumn Olive (*Elaeagnus Umbellata*)
Multiflora Roase (*Rosa multiflora*)
Purple Loosestrife (*Lythrum salicaria*)
Tree of Heaven (*Ailanthus altissima*)
Black (*Juglans nigra*)
Silver Maple (*Acer Saccharinum*)
Black Locust (*Robinia pseudo-acacia*)
Catalpa (sp.*)
Cotton wood (*Populus deltoides*)
Poplar

*Indicates numerous species.

2003 MAINTENANCE AND REPLACEMENT REQUIREMENTS

The lot owner shall be responsible for the maintenance of all landscaping. The following requirements shall apply:

- A.** Landscape material shall not interfere with public utilities, restrict pedestrian or vehicular access, or otherwise constitute a traffic hazard.
- B.** Within two years of installation (or incorporation of existing vegetation), all trees, shrubs, ground covers and other plant materials shall be replaced if they fail to thrive.
- C.** Replacement plants shall conform to the approved plan. Dead or unhealthy plants shall be replaced within the next planting season.
- D.** As part of the Site Plan, a bond, escrow, or other suitable guarantee shall be filed with the Zoning Inspector to ensure the landscape material is installed and maintained for a two (2) year period. No Zoning Certificate shall be issued until the bond, escrow or other suitable guarantee is received.

SECTION 21

PARKING REQUIREMENTS

2100 GENERAL PARKING REQUIREMENTS

Any building, structure or use of land that is constructed, enlarged, or used shall provide off-street parking spaces for automobiles in accordance with the following minimum provisions:

2101 OFF-STREET PARKING DESIGN STANDARDS

All off-street parking including driveways, entrances, exits, circulation and maneuvering areas, aisles and interior lanes, and parking spaces shall be in accordance with the following minimum standards and specifications:

2101.01 Parking Space Dimensions

All new or altered parking lots shall conform to the parking space stall width and length and aisle width, as set out in Table 1 and illustrated in Figure 1.

TABLE 1

<u>DIMENSION</u>	<u>ANGLE</u>			
	<u>45</u>	<u>60</u>	<u>75</u>	<u>90</u>
A. STALL DEPTH TO WALL	17	18.5	19	18
B. STALL DEPTH PARALLEL TO VEHICLE	18	18	18	18
C. VEHICLE AISLE WIDTH	12	18	22	25
D. STALL DEPTH TO INTERLOCK	15	17	18	18
E. STALL DEPTH REDUCTION DUE TO INTERLOCK	2	1.5	1	0
F. STALL WIDTH PARALLEL TO AISLE 1	12.7	10.4	9.3	9
G. STALL WIDTH PERPENDICULAR TO VEHICLE	9	9	9	9
H. MODULE WIDTH WALL TO WALL	45	54	60	61
I. MODULE WIDTH INTERLOCK TO INTERLOCK	42	51	52	51

FIGURE 1

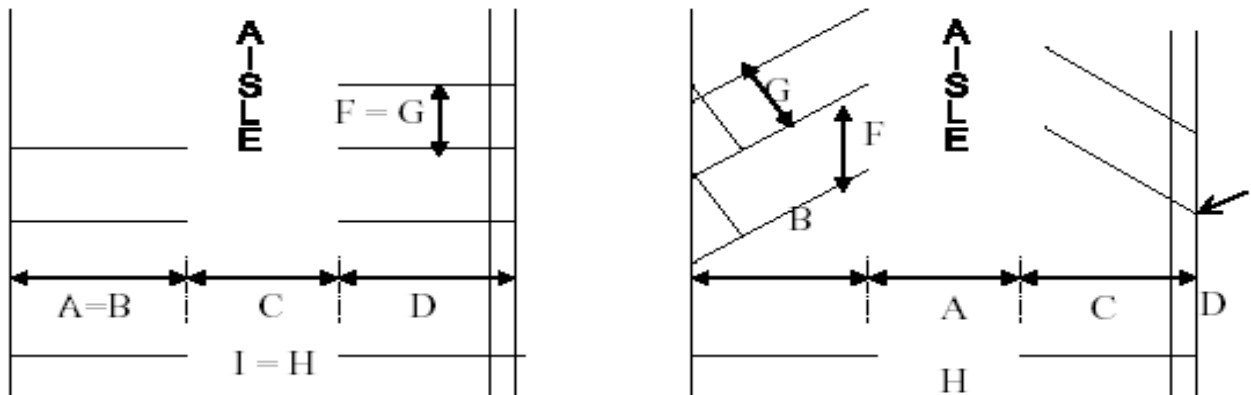

Exceptions to TABLE 1:

- A.** For bumper overhang deduct one and one-half (1 ½') feet from stall depth to wall or three (3') feet from wall to wall for 45 degree and 60 degree parking. The equivalent dimensions for seventy-five (75) degree and ninety (90) degree parking are two (2') feet and four (4') feet respectively.
- B.** Where natural and/or man-made obstacles, obstructions, or other features such as landscaping, support columns, or grade difference exist, the Board of Township trustees may approve a reduction in required stall width, length, and/or aisle width as part of the Site Plan review process. In all instances where a reduction is requested, emergency vehicle access shall be considered and incorporated into the parking lot design.

2101.02 Access

For single or two family residential dwellings, driveways shall be a minimum of nine (9') feet in width. For all other uses, driveways shall be a minimum width of twenty-two (22') feet.

2101.03 Setbacks

- A.** No parking shall be permitted within the front yard of any residential property except on asphalt, concrete or gravel.
- B.** Off-street parking areas in commercial districts shall not be located in the required landscape strips, or closer than five (5') feet from any side or rear property line. No part of any loading space shall be permitted closer than fifty (50') feet to any residential district nor closer than five (5') feet to any right-of-way.
- C.** Whenever any commercial, industrial, or public use/open space district adjoins a residential district, the off-street parking for the non-residential use may not be located within twenty (20') feet from the residential district boundary, and shall not be located within ten (10') feet of any right-of-way.

2101.04 Screening

See Section 20 – Landscaping Requirements.

2101.05 Surfacing

All off-street parking spaces, driveways, aisles, entrances, exits, circulation and maneuvering areas, and interior lanes for all nonresidential uses, shall be surfaced prior to occupancy of the building. Surfacing shall be accomplished with asphalt, concrete or masonry-type material. Stone or gravel is not considered a masonry-type material.

- 2101.06 Drainage**
All parking spaces, driveways, entrances, exits, circulation and maneuvering areas and interior lanes, shall be graded and drained so as to dispose of surface water which might accumulate within or upon such area, and shall be designed to prevent the excess drainage of surface water onto adjacent properties, walkways, or onto the public roads. Adequate arrangements shall be made to insure acceptable diversion to an adequate storm water drainage system.
- 2101.07 Lighting**
Any lighting used to illuminate any off-street parking areas shall be so arranged as to reflect light away from adjoining residential properties or public way.
- 2101.08 Striping**
All parking areas shall be marked with paint lines, curbs, or some other manner approved by the Zoning Inspector, and shall be clearly identified.
- 2101.09 Maintenance**
Parking areas shall be maintained in good condition and free of dust, trash, or other debris.
- 2101.10 Signs**
Where necessary, entrances, exits, and the intended circulation pattern of the parking area shall be clearly marked.
- 2101.11 Parking of Commercial Vehicles**
Truck tractors and/or truck trailers, dump trucks, and other vehicles with a total maximum gross vehicle weight of six (6) tons or greater shall not be parked, stored or kept on any parcel except when making deliveries in any A/R or R District. An exemption to this Section is authorized subject to conformance with all of the following criteria:
- A. Only one (1) commercial vehicle is parked on the premises;
 - B. The commercial vehicle is parked inside a completely enclosed structure at all times; and
 - C. The parcel on which the commercial vehicle is parked has a minimum size of one and one half (1 ½) acre.
- (Vehicles used for agricultural purposes are exempt from this Section.)
- 2101.12 Shared Parking**
Two (2) or more non-residential uses may jointly provide and use parking spaces when the hours of operation do not normally overlap, provided that a written agreement is submitted and the request is first approved by Jerusalem Township Legal Counsel and the Board of Zoning Appeals.

2102 DETERMINATION OF REQUIRED SPACES

In computing the number of parking spaces required by this Resolution, the following shall apply:

- A. Whenever there is more than one type of use on a parcel, the area allocated for each specific use must be identified.
- B. Each separate or distinct use on the site shall meet its own specific parking space requirements. Any proposed use on a site which cannot satisfy the parking requirements shall be strictly prohibited.
- C. The total number of parking spaces required on-site shall be the sum of the requirements for each use on the premises.
- D. Whenever the total sum computed for required off-street parking or loading spaces includes a fraction, the next higher whole number shall be required.
- E. For purposes of off-street parking and loading requirements, "gross floor area" shall include all of the area on each floor whether or not such area is enclosed by walls, exclusive of interior areas used for off-street parking or loading facility.
- F. Where seating capacity is the standard for determining parking space requirements, the capacity means the number of seating units, or each eight (18) lineal inches of benches, or pews, unless occupancy standards set by the State of Ohio Fire Marshal, require a greater number of parking spaces, which shall then be the minimum number of parking spaces required.
- G. The parking space requirements for a use not specifically identified in this Resolution shall be the parking requirements for the use that is most similar.

2103 PARKING SPACE REQUIREMENTS

2103.01 Residential Uses:

Single-family or two-family dwelling: Two (2) per dwelling unit.

Multi-family with three or more dwelling units: Two (2) per dwelling unit.

Multi-family with three or more dwelling units designated exclusively for occupancy by the elderly or physically disabled (including congregate housing): One-half (½) per dwelling unit; plus an area on the site reserved for future parking to accommodate one parking space per dwelling unit.

Assisted living facilities/Nursing Homes: One (1) for every three beds.

Rooming or boarding house: One (1) for each sleeping room.

2103.02 Commercial Uses:

Sexually Oriented Business: One (1) for each seventy-five (75) square feet of gross floor area.

Amusement arcade: One (1) for each two-hundred (200) square feet of gross floor area.

Auditorium, stadium, theater, conference center, or large place of assembly: One (1) for each thirty (30) square feet of gross floor area of the auditorium or assembly space.

Automobile car wash, automatic, self-service: Two (2) per site. A washing space is not a parking space.

Automotive repair: Two (2) per bay. A service bay is not a parking space.

Automobile sales: One (1) for each five thousand (5,000) square feet of developed lot area used for vehicle display and one (1) for each three hundred (300) square feet of gross floor area.

Bank or financial institution: One (1) for every two hundred (200) square feet of floor area.

Barber and beauty shop: One (1) for every two hundred (200) square feet of gross floor area.

Bowling Alley: Five (5) per alley or lane.

Funeral Home: One (1) for every one hundred fifty (150) square feet of gross floor area.

General Office: One (1) for each three hundred (300) square feet of gross floor area.

Golf Course: Six (6) for each hole.

Hotel or motel: One (1) per guest room and one (1) for every one hundred (100) square feet of gross floor area of bar, restaurant, and conference rooms.

Salvage Yard: Five (5) spaces per acre.

Medical or Dental Office or Clinic: One (1) for each two hundred (200) square feet of gross floor area.

Medical Marijuana Dispensary: One for each 250 square feet of gross floor area.
(Rev 12-20-17, Z28-C142)

Meeting or Reception Hall: One (1) for each seventy-five (75) square feet of gross floor area.

Outdoor recreation: One (1) for each five hundred (500) square feet of use area.

Self-service storage facility: Four (4) plus one (1) space per employee.

Retail: One (1) for each two hundred (200) square feet of gross floor area.

Restaurant or tavern: One (1) for each seventy-five (75) square feet of gross floor area or one (1) for each hundred twenty-five (125) square feet of gross floor area when located within a multi-tenant building.

Any other type of commercial use: One (1) for each two hundred fifty (250) square feet of gross floor area.

2103.03

Institutional Uses:

Day Care Facility: One (1) space per each two hundred fifty (250) square feet of gross floor area.

Church or place of worship: One (1) for every five (5) seats in the main assembly area/auditorium.

Club or lodge: One (1) for each five (5) members.

Correctional Facilities: One (1) for every two (2) beds.

Elementary school (K-9): Two (2) for each classroom or one (1) for every five (5) seats in the main auditorium, which ever is greater.

Hospital: One (1) space for every four (4) beds.

Library, museum, or art gallery: Ten (10) plus one (1) for each three hundred (300) square feet of gross floor area in excess of two thousand (2,000) square feet.

2103.04

Industrial Uses

Manufacturing, Utility, Research, and Development Facilities: One (1) for every two (2) employees on the shift of the highest number of employees and one (1) for each motor vehicle used in the business.

Medical Marijuana Cultivation, Testing and Processing facilities: One space per each employee. (Rev 12-20-17, Z28-C142)

Truck Terminal: One (1) space per loading dock.

2104 OFF-STREET AREAS WITH DRIVE-UP/DRIVE-THRU SERVICE

Establishments shall provide off-street vehicle queuing areas in accordance with the following requirements:

- A. Photo pickups, restaurants, drive-thru beverage docks, and other similar commercial establishments that can normally serve customers in three (3) minutes or less shall provide no less than five (5) vehicle queuing spaces per window, not including the space at the window. Drive-in restaurants and other similar uses which require an additional stopping

point for ordering shall provide a minimum of three (3) additional queuing spaces for each stopping point.

- B.** Other commercial establishments such as banks, savings and loan offices, or other similar facilities with service or money windows shall provide no less than four (4) queuing spaces per window.
- C.** Self-serve automobile washing facilities shall provide no less than four (4) queuing spaces per stall. All other automobiles washing facilities shall provide a minimum of ten (10) queuing spaces per entrance.
- D.** Motor vehicles service stations shall provide no less than two (2) queuing spaces for each accessible side of a gasoline pump island. Gasoline pumps shall not be located closer than fifteen (15') feet to any right-of-way line.

2105 PARKING OF DISABLED VEHICLES AND WATERCRAFT

The parking of a disabled vehicle or watercraft more than one three (3) days on a lot shall be prohibited in all Agricultural, Residential or Commercial Districts, except such vehicle or watercraft may be stored in an enclosed garage or other accessory building, provided that no business shall be conducted in connection therewith while such vehicle or watercraft is parked or stored.

2106 PARKING AND STORAGE OF RECREATIONAL VEHICLES, TRAILERS AND WATERCRAFT

Storage of recreational vehicles, watercraft and/or utility trailers, are permitted in an "A/R" or "R" District when the following conditions and requirements are complied with:

- A.** No such vehicles, watercraft or trailers shall be parked or stored in a front yard.
- H.** Such vehicles, watercraft or trailers may be parked or stored in a rear yard, but not within ten (10') feet of any lot line.
- I.** Such vehicles, watercraft or trailers parked or stored on a lot shall not have fixed connections to electricity, water, gas or sanitary sewer facilities, and at no time shall this equipment be used for living or housekeeping purposes.
- J.** Only two (2) recreational vehicles, watercraft or trailers single or in combination, shall be parked or stored in an "A/R" or any "R" District.
- K.** Notwithstanding the provisions of this section, such vehicles, watercraft or trailers may be parked anywhere on the premises for loading and unloading purposes, for a period of not more than seventy-two (72) hours.
- F.** Recreational vehicles, watercraft and/or utility trailers parked or stored on a vacant parcel shall be prohibited except where permitted on a commercial lot

SECTION 22

PROCEDURES AND REQUIREMENTS FOR SPECIAL USES

- 2200 PURPOSE** In addition to those uses specifically permitted in each Zoning District, there are certain uses that are necessary for the good of the public, but due to the potential impact on the community, require additional review and consideration.
- 2201 STANDARDS** The Zoning Commission and the Board of Township Trustees shall review each proposed Special Use and shall consider the following:
- A. Will the proposal be in accordance with the general objectives, or with any specific objectives of the Jerusalem Township Land Use Plan (and as amended);
 - B. Is the proposal harmonious with the existing or intended character of the general vicinity of the lot and will it change the essential character of the area;
 - C. Will the proposal not be hazardous or disturbing to existing or future neighboring uses;
 - D. Will the proposal be served adequately by essential public facilities and services;
 - E. The proposal will involve uses, activities, processes, materials, equipment, and conditions of operation that will be detrimental to any persons, property, or the general welfare by reason of excessive production of traffic, noise, smoke, fumes, glare, vibration or odors?
- 2202 PROCEDURE**
A Special Use may be requested by the lot owner. The procedure is set forth in Section 23 – Zoning Changes and Text Amendments.
- 2203 CONDITIONS OF APPROVAL** In granting any Special Use, the Board of Township Trustees may require the following items to protect the general health, safety and welfare of the community:
- A. Increased landscaping requirements.
 - B. Screening between any proposed Special Use and adjacent property and/or roadway.
 - C. The location of parking areas.
 - D. Regulating the hours and/or days of operation.
 - E. Lighting locations, intensity and areas to be illuminated.
 - F. Any other item deemed necessary to protect the general health, safety and welfare of the community.
- 2204 EXPIRATION OR REVOCATION OF SPECIAL USE** A Special Use shall automatically expire if the Special Use has not been instituted or utilized within one (1) year from the date on which the Special Use was granted by the Board of Township Trustees, or for any reason the use shall cease for more than a two (2) year continuous period. Violation of any condition(s) of approval shall be cause for the revocation of the Special Use by the Board of Township Trustees.

SECTION 23

ZONING CHANGES AND TEXT AMENDMENTS

2300 AUTHORITY

Whenever the public necessity, convenience, general welfare or good zoning practice requires, the Board of Township Trustees may, by resolution, after the Zoning Commission recommendations, and subject to the procedures provided by law, amend, supplement, change or repeal the regulation, restrictions and district boundaries or classification of property, now or hereafter established by this resolution or amendments hereof.

2301 PROCEDURES

Amendments to this Zoning Resolution may be initiated in one of the following ways. The Board of Township Trustees shall upon passage of such resolution, certify it to the Zoning Commission.

- A. By passage of a resolution by the Board of Township Trustees;
- B. By a motion of the Zoning Commission;
- C. By the filing of an application by at least one (1) owner, or an authorized agent of the owner of the property within the area proposed to be changed.

2302 APPLICATION AND FEES

The application for any change of district boundaries or classifications of property shall be made on forms obtainable at the office of the Zoning Inspector. The application shall be accompanied by information as may be prescribed by the Zoning Commission, and verified by the owner or authorized agent as to accuracy. A fee shall be paid upon the filing of the application and no action shall be taken on an application until all fees are paid in full and all required information is provided.

2303 TRANSMITTAL TO THE LUCAS COUNTY PLAN COMMISSION

Within five (5) working days after the adoption of such motion or the certification of such Resolution, or the filing of such application, the Commission shall transmit a copy thereof together with text and map to the Lucas County Planning Commission. The Lucas County Planning Commission may recommend the approval or denial of the proposed amendment or supplement or the approval of some modification thereof and shall submit such recommendation to the Zoning Commission. Such recommendation shall be considered at the public hearing held by the Zoning Commission on such proposed amendment or supplement.

2304 HEARING AND NOTICE BY ZONING COMMISSION

Upon the adoption of such motion, or the certification of such resolution, or the filing of such application as covered by paragraph 2201 of this Section the Zoning Commission shall hold a public hearing thereon. The Zoning Commission shall set a date for the public hearing, which date shall not be less than twenty (20) nor more than forty (40) days from the date of the certification of such resolution or the date of the adoption of such motion or the date of the filing of such application. Notice of such hearing shall be given as follows:

- A. The applicant shall post and maintain an on-site notice as required provided by the Zoning Office. The applicant shall remove the posted notice within ten (10) days after the decision of the Board of Township Trustees. No one except the applicant, agent or Township shall remove or tamper with any such notice during the time it is required to be posted and maintained.
- B. A notice shall be published in one (1) or more newspapers of general circulation in the township at least ten (10) days before the date of such hearing. The published and mailed notices shall set forth the time and place of the public hearing, the nature of the proposed amendment or supplement, and a statement that after the conclusion of such hearing the matter will be referred for further determination to the Board of Township Trustees.
- C. If the proposed amendment or supplement intends to rezone ten (10) or less parcels of land, as listed on the tax duplicate, written notice of the hearing shall be mailed by the Zoning Commission, by first class mail, at least (10) days before the date of the public hearing, to all owners of property within and contiguous to and directly across the street from such area proposed to be rezoned or redistricted, to the addresses of such owners appearing on the Lucas County Auditor's current tax list. The failure of delivery of such notice shall not invalidate any such amendment or supplement.

2305 RECOMMENDATION BY ZONING COMMISSION

The Zoning Commission shall study the proposed change in the terms of public necessity, convenience, general welfare, and good zoning practice. The Zoning Commission shall, within thirty (30) days after such hearing, recommend the approval or denial of the proposed amendment or supplement or the approval of some modification thereof, and submit such recommendation together with such application or resolution, the text and map pertaining thereto and the recommendation of the Lucas County Planning Commission thereon, to the Board of Township Trustees.

2306 PUBLIC HEARING AND NOTICE BY THE BOARD OF TOWNSHIP TRUSTEES

Within thirty (30) days from the receipt of the recommendation of the Zoning Commission, the Board of Township trustees shall hold a public hearing. Notice of the public hearing shall be given by the Board of Township Trustees with at least one (1) publication in a local newspaper of general circulation at least ten (10) days before the date of the public hearing. This notice shall set forth the time and place of the public hearing and the nature of the proposed request.

2307 ACTION BY THE BOARD OF TOWNSHIP TRUSTEES

Within twenty (20) days after such public hearing, the Board of Township Trustees shall either adopt or deny the recommendations of the Zoning Commission or adopt some modification thereof. In the event the Board of Township Trustees deny or modify the recommendation of the Zoning Commission, the unanimous vote of the Board of Township Trustees shall be required.

2308 EFFECTIVE DATE AND REFERENDUM

- A.** Such amendment or supplement adopted by the Board of Township Trustees shall become effective in thirty (30) days after the date of such adoption unless within thirty (30) days after the adoption of the amendment or supplement there is presented to the Township Trustees a petition, signed by a number of registered electors residing in the unincorporated area of the Township or part thereof included in the zoning plan equal to not less than eight percent (8%) of the total vote cast for all candidates for governor in such area at the most recent general election at which a governor was elected, requesting the Board of Trustees to submit the amendment to the electors of such area for approval or rejection at a special election to be held on the day of the next primary or general election.
- B.** No amendment or supplement for which such referendum vote has been requested shall be put into effect unless a majority of the vote cast on the issue is in favor of the amendment. Upon certification by the Board of Elections that the amendment has been approved by the voters it shall take immediate effect.

SECTION 24

ENFORCEMENT

2400 ZONING INSPECTOR

The Zoning Inspector shall be appointed by the Board of Township Trustees and shall have the following responsibilities:

- A. Review Applications for Zoning Certificates, Site Plan Review, Special Uses, and Zoning Change.
- B. On-Site Inspections.
- C. Investigation of violations and enforcement of this Resolution.
- D. Maintain records of zoning activity including non-conforming and Special Uses.

2401 ZONING CERTIFICATE REQUIRED

No building or other structure, including temporary structure, shall be constructed, moved, added to, altered, nor shall any building, structure, or land be established or changed in use without a Zoning Certificate issued by the Zoning Inspector. Zoning Certificates shall be issued only in conformity with the provisions of this Resolution unless the Zoning Inspector receives a written order from the Board of Zoning Appeals deciding an appeal or variance. Zoning Certificates may be issued for the following:

2401.01 Construction

Before any structure, as defined in this Resolution is built, erected, enlarged, or placed on a property, a Zoning Certificate shall be required. The Zoning Inspector shall issue a Zoning Certificate when satisfied that according to the information submitted by the applicant, the proposed structure will conform to all requirements of this Resolution.

2401.02 Change of Use

When the use of a property or a building or structure changes, a Zoning Certificate is required. The Zoning Inspector shall issue a Zoning Certificate when the requirements of this Resolution are met.

2401.03 Signs

Before any sign, except those exempted in Section 1804, may be placed, constructed, or structurally altered, on or attached to a building, or on a parcel of land, a Zoning Certificate is required.

2402 APPROVAL OF ZONING CERTIFICATE

Within twenty (20) days after the receipt of an application for a Zoning Certificate, the Zoning Inspector shall either approve or disapprove the application in conformance with the provisions of this Resolution. All Zoning Certificates shall, however, be conditional upon the commencement of work within six (6) months. All Zoning Certificates shall expire after a one (1) year period but may be renewed subject to the filing of an application with the Zoning Inspector.

2403 ENFORCEMENT AND PENALTIES

- A.** This Resolution shall be enforced by the Board of Township Trustees or such enforcement officer as may be designated by the Board of Township Trustees, who shall in no case grant any Zoning Certificate if the building or use would be in violation of any of the provisions of this Resolution.
- B.** Except as expressly provided in this Resolution, it shall be unlawful to locate, erect, construct, reconstruct, enlarge, structurally alter, or use any building or structure or use and land without obtaining a Zoning Certificate.
- C.** Any Zoning Certificate issued upon a false statement of any fact which is material to the issuance thereof shall be void. Whenever the fact of such false statement shall be established to the satisfaction of the Board of Township Trustees, the Zoning Certificate shall be revoked by notice in writing to be delivered to the holder of the void Zoning Certificate upon the premises concerned, or in case such holder be not found there, by posting the said notice of revocation in some conspicuous place upon the said premises. Any person who shall proceed, thereafter, with such work or use without having obtained a new Zoning Certificate, in accordance with this Resolution, shall be deemed guilty of violation thereof.
- D.** In case any building is located, erected, constructed, reconstructed, enlarged, changed, maintained or used, or any land is or is proposed to be used in violation of this Resolution, the Board of Township Trustees, the County Prosecutor, the Township Zoning Inspector, or any adjacent or neighboring property owner who would be especially damaged by such violation, in addition to other remedies provided by law, may institute injunction, mandamus, abatement, or any other appropriate action or proceedings to prevent, enjoin, abate, or remove such unlawful location, erection, construction, reconstruction, enlargement, change, maintenance, or use.
- E.** Any person, firm, or corporation violating any provision of this Resolution shall be deemed guilty of a misdemeanor and, upon conviction thereof, shall be fined not more than one hundred dollars (\$100.00). Each and every day, during which illegal location, erection, construction, reconstruction, enlargement, change, maintenance, or use continues, may be deemed a separate offense.
- F.** Failure to obtain a Zoning Certificate may result in paying three (3) times the regular fee schedule.

2404 SCHEDULE OF FEES, CHARGES, AND EXPENSES

The Board of Township Trustees shall, by Resolution, establish a schedule of fees, charges, and expenses and a collection procedure for Zoning Certificates, amendments, appeals, variances, special use permits, site plan approvals, and other matters pertaining to the administration and enforcement of this Resolution requiring investigations, inspections, legal advertising, postage, and other expenses. The schedule of fees shall be available in the Office of the Zoning Inspector, and may be amended only by the Board of Township Trustees. No Zoning Certificate will be issued until the appropriate fee has been paid. No hearing or appeal will be conducted until the fee has been paid.

SECTION 25

ZONING COMMISSION

2500 JERUSALEM TOWNSHIP ZONING COMMISSION

The Jerusalem Township Zoning Commission shall be composed of five (5) members who reside in the unincorporated area of Jerusalem Township and who shall be appointed by the Board of Township Trustees. Vacancies shall be appointed by the Board of Township Trustees for any unexpired term. The Board of Township Trustees may appoint alternate members in accordance with the provisions of the ORC.

2501 ORGANIZATION

The Zoning Commission shall organize and keep a written record of its actions and determinations, adopt rules and procedures to effectively carry out duties and obligations, all of which shall be filed in the Office of the Township Clerk and shall be a public record.

2502 MEETINGS

At the first meeting of each year the Zoning Commission shall elect a Chairperson and Vice-Chairperson for a term of one (1) year. There shall be a fixed place of the meeting and all meetings shall be open to the public. The Zoning Commission shall keep a record of its proceedings showing the action of the Zoning Commission and showing the vote of each member on each request considered. All recommendations of the Zoning Commission shall be filed in the Office of the Township Clerk and shall be a public record. A quorum to conduct a meeting shall consist of at least three (3) members of the Zoning Commission.

2503 DUTIES OF THE ZONING COMMISSION

The Township Zoning Commission shall have the following authority:

- A. Initiate proposed amendments to this Resolution;
- B. Consider, review, and recommend all proposed amendments to the Board of Township Trustees;
- C. Consider, review, and approve or deny on all site plans;
- D. Consider and review all proposed Special Uses and make recommendations to the Board of Township Trustees.

SECTION 26

BOARD OF ZONING APPEALS

2600 JERUSALEM TOWNSHIP BOARD OF ZONING APPEALS

The Jerusalem Township Board of Zoning Appeals shall consist of five (5) members who shall be residents of the unincorporated area of Jerusalem Township. The terms of all members shall be so arranged so that the term of one (1) member expires each year. The Board of Township Trustees shall fill by appointment any vacancies including unexpired terms. The Board of Township Trustees may appoint alternate members in accordance with the provisions of the ORC.

2601 MEETINGS

At the first meeting of each year the Board of Zoning Appeals shall elect a Chairperson and Vice-Chairperson for a term of one (1) year. There shall be a fixed place of the meeting and all meetings shall be open to the public. The Board of Zoning Appeals shall keep a record of its proceedings showing the action of the Board of Zoning Appeals and showing the vote of each member on each request considered. All records of the Board of Zoning Appeals shall be filed in the Office of the Township Clerk and shall be a public record. A quorum to conduct a meeting shall consist of at least three (3) members of the Board of Zoning Appeals.

2602 DUTIES OF THE BOARD OF ZONING APPEALS

The Board of Zoning Appeals shall have the following authority:

- A. To organize, adopt rules, hold meetings and keep records as required by law.
- B. To hear and decide appeals where it is alleged there is error in any order, requirement, decision, or determinations made by the Zoning Inspector in the enforcement of this Resolution. This includes hearing and deciding matters of interpretation of the provisions of the text of this Resolution and the "Official Jerusalem Township Zoning Map".
- C. To authorize, upon appeal, in specific cases such variance from the terms of this Resolution as will not be contrary to the public interest, where owing to special conditions, a literal enforcement of the Resolution will result in unnecessary hardship, and so that the spirit of this Resolution shall be observed and substantial justice done. No variance shall be granted except in conformance with the provisions of Section 2604 of this Resolution.
- D. To allow the construction of more than one (1) main building on a single parcel unless specifically permitted in Section 1605 – Supplemental Regulations.

2603 APPEAL REQUIREMENTS

Appeals to the Board of Zoning Appeals may be taken by any person aggrieved or by any officer of the Township affected by any decision of the Zoning Inspector. Such appeal shall be taken within twenty (20) days after the decision by filing with the Board of Zoning Appeals, a notice of appeal specifying the grounds. The following information shall be included in any application brought before the Board of Zoning Appeals for consideration of an appeal or matter of interpretation:

- A. The request must include the action or order of the Zoning Inspector such as the citation of zoning violation and/or a Zoning Certificate being denied or revoked.

- B. The specific reference, including chapter(s) and sections(s), of the zoning text or portions of the “Official Jerusalem Township Zoning Map” that may be appealed.
- C. The facts and information showing the basis of the appeal, including factors or characteristics unique to a parcel.
- D. The specific remedy proposed or proposed interpretation shall be described.

2604 REQUIREMENTS FOR A VARIANCE REQUEST AND APPROVAL

The Board of Zoning Appeals may authorize upon appeal, in specific cases, such variance from the terms of the Zoning Resolution as will not be contrary to the public interest, where, owing to specific conditions, a literal enforcement of the Resolution will result in unnecessary hardship, and so that the spirit of the Resolution shall be observed and substantial justice done. The Board of Zoning Appeals shall consider the following:

- A. That due to exceptional narrowness, shallowness, or shape or exceptional topographic conditions or other extraordinary situation or condition of a lot, the strict application of the terms of this Resolution would result in peculiar and exceptional practical difficulties.
- B. That special circumstances or conditions applying to the building or land in question are peculiar to such lot or property and do not apply generally to other land or buildings in the vicinity.
- C. That a variance from the strict application is necessary to relieve such difficulties or hardship, and that such relief may be granted without substantial detriment to the public good and without substantially altering the intent of this Resolution.
- D. The granting of the application is necessary for the preservation and enjoyment of a substantial property right and not merely to serve as a convenience to the applicant.
- E. The condition from which relief or a variance sought did not result from action by the applicant.
- F. No variance may be applied for or granted which would allow a use that is not allowed in a zoning district.
- G. The authorization of a variance will not impair an adequate supply of light and air to adjacent property or unreasonably increase the congestion in public streets, or increase the danger of fire or imperil the public safety or unreasonably diminish or impair the health, safety, convenience or general welfare of the inhabitants of the Township.

2605 CONDITIONS OF APPROVAL

In granting a variance, the Board of Zoning Appeals may stipulate the manner in which the variance shall be carried out, and may require other improvements and safeguards for the protection of public health, safety, and welfare. In such cases the Board of Zoning Appeals may attach conditions.

2606 APPLICATIONS

All applications shall be in writing, shall be signed by the owner of the property involved or an authorized agent or attorney, shall specify the request and grounds thereof, and shall be filed in the Office of the Zoning Inspector.

2607 PUBLIC HEARING AND NOTICE

- A. Once the application has been received, the applicant must post and maintain an on-site notice as provided. The applicant is responsible for removing the posted notice within ten (10) days after the decision of the Board of Zoning Appeals. No one except the applicant, agent or Township shall remove or tamper with any such notice during the time it is required to be posted and maintained.

- B. The Board of Zoning Appeals shall fix a reasonable time for the hearing of a matter to come before it and shall give at least ten (10) days notice to the parties in interest, stating the time and place. In addition, notice of such public hearing shall be given in one publication in one or more newspapers of general circulation at least ten (10) days before the date of such hearing. The Board of Zoning Appeals shall make its findings and determination in writing within sixty (60) days from the date of the filing of the request. At the hearings, any party may appear in person by agent or by attorney and shall be given the opportunity to be heard. A copy of the findings and determination made by the Board of Zoning Appeals shall be transmitted to the applicant within fourteen (14) days following their decision.

SECTION 27

DEFINITIONS

DEFINITIONS

For the purpose of this Resolution certain terms and words are defined in Section 17 – Signs and Outdoor Advertising and in this section. Words used in the present tense include the future, and the plural includes the singular, and the singular the plural. The word "shall" is mandatory; "occupied" or "used" shall be considered as though followed by the words or intended, arranged, or designed to be used or occupied. Except where specifically defined, all words used in this Resolution shall carry their customary meanings.

Abandoned: To cease or discontinue a use or activity without intent to resume, but excluding temporary or short term interruptions to a use or activity during periods of remodeling, maintaining, or otherwise improving or rearranging a facility, or during normal periods of vacation or seasonal closure.

Accessory Structure: A subordinate structure including those without a permanent foundation, detached from but located on the same lot as the principal structure, the use of which is incidental and accessory to that of the principal structure. It does not include tents, portable structures, pods, converted trailers or shipping containers. (Rev 12-20-17, Z28-C143)

Accessory Use: A use incidental to, and on the same lot as, a principal use. Accessory uses include any use of a subordinate nature to the principal use on the same lot.

Agriculture: The use of land for farming, dairying, pasturage, agriculture, horticulture, viticulture, animal and poultry husbandry. Agricultural shall not include kennels and boarding of livestock and domesticated animals, as herein defined.

Agricultural Implement Sales and Rental: The sale or rental of new or used agricultural implements and equipment to be displayed for sale on the premises.

Agricultural Product Sales: The sale of goods, products, or services provided by person(s) engaged in agriculture.

Airport or Aircraft Landing Field: Any landing area, runway or other facility designed, used, or intended to be used either publicly, or by any person for the landing and taking off of aircraft, including all necessary building and open spaces.

All Terrain Vehicles: Self propelled vehicles designed for off-road usage on land and/or water. These include, but not limited to, snowmobiles, dirt bikes, 3-wheel/4-wheel ATV's, and personal watercraft.

Alley: A public thoroughfare less than thirty (30') feet wide.

Alteration, Structural: Any change which would tend to prolong the life of the supporting members of a building or structure, such as bearing walls, columns, beams, or girders.

Animal Care Facilities: Structures, buildings, or enclosures used for medical treatment, care and temporary housing of animals, receiving treatment, with temporary housing being limited to forty-eight (48) hours. Uses include but not limited to veterinary clinics and animal hospitals.

Apartment: Same as **Dwelling Unit**.

Apartment Hotel: A building or portion thereof designed for or containing both individual guest rooms or suites of rooms and dwelling units.

Apartment House: Same as **Dwelling, Multiple**.

Applicant: The land owner or his authorized agent, who requests a zoning permit as authorized by this Resolution.

Auction Market: A building, structure, or site which primary use is for selling of goods, merchandise, land etc. by a bidding process.

Authorized Agent: A person with legal permission to represent a person or business entity.

Automobile Service Station: See **Motor Vehicle Service Station**.

Automobile and Trailer Sales Area: See **Motor Vehicle Sales and Rental**.

Automobile Wrecking/Salvage Yard: See **Motor Vehicle Salvage Yard**.

Basement: A story partly or wholly underground. For purpose of height measurement, a basement shall be counted as a story where more than one-half (1/2) of its height is above the average level of the adjoining ground.

Bed and Breakfast: An establishment located within a detached house that is the principal residence of the operator, where short-term lodging is offered for compensation and which includes the service of one or more meals to guests.

Billboard: Any sign used as an outdoor display for the purpose of making anything known, the origin of point of sale of which is remote from said display.

Board: Shall mean the Board of Zoning Appeals.

Board of Township Trustees: The Board of Township Trustees for Jerusalem Township, Lucas County, Ohio.

Boarding House: A building or portion thereof, other than a hotel where meals, or lodging and meals for four (4) or more persons are provided for compensation.

Boarding of Livestock and Domesticated Animals: Stabling, housing and feeding of animals for compensation. or for use in a commercial activity, exhibit or for other commercial/recreational purposes.

Boat Storage: The storage of boats, similar watercraft, personal watercraft, and marine equipment.

Building: Any structure, including a roof supported by walls, designed or built for the support, enclosure, shelter or protection of persons, animals, chattels or property of any kind.

Building Area: The space remaining on a lot after the minimum open space requirements (coverage, yards, setbacks) have been met.

Building, Community: A building for social, education, and recreational activities or a neighborhood or community, provided any such use is not operated for commercial gain.

Building Coverage: The amount of land covered or permitted to be covered by a building measured on a horizontal plane at mean grade level and excluding uncovered porches, terraces and steps.

Building Line: A setback line for a main building on a platted lot.

Building, Main: A building in which is conducted the principal use of the lot on which it is situated.

Building Height: The vertical distance measured from the adjoining road centerline grade to the highest point of the roof surface, if a flat roof; to the deckline of a mansard roof; and to the mean height level between eaves and ridges for a gable, hip, or gambrel roof, provided that where buildings are set back **200 feet or greater** from the street line, the height of the building ~~may~~ **shall** be measured from the average elevation of the finished grade along the front of the building.

Bus Shelter: An open structure with a roof used as a protection or shield from wind, rain, snow etc. Usually a place for persons to stay awaiting a bus or passenger vehicle.

Business: An office, salesroom, store, site or shop engaged in the supply/distribution or sale of commodities, products and services.

Business, General: Retail and service establishments which, in addition to catering to the community residents' and workers' daily needs for convenience goods and services, also include establishments offering comparative type shopping facilities. General business includes, but is not limited to, supermarkets and stores and for the sale of drugs, hardware, appliances, furniture, apparel, footwear, business and personal services, professional services, offices and other similar or related activities which can be grouped by design into a unified shopping center.

Business, Highway: Includes commercial uses requiring locations on major thoroughfares and at their principal intersections. Highway uses include motels, motor vehicle service stations, motor vehicle repair, restaurants, drive-in establishments, construction and contractors supply, services and material storage, commercial recreation and similar commercial activities, when maintained inside an enclosed building.

Business, Neighborhood: Retail and service establishments which primarily serve local market areas and can be located in close proximity to or within Residential Districts without creating undue vehicular congestion, excessive noise or other objectionable influence. To prevent congestion, local retail and service uses include only those enterprises which normally employ less than ten (10) persons. Permitted Uses include drug stores, beauty salons, barber shops, carry-outs, dry cleaning and laundry pickup facilities, and hardware and grocery stores if less than ten thousand (10,000) square feet of floor area. Other small businesses of an equally restricted and local nature may be permitted, based on the discretion of the Board of Zoning Appeals.

Campground: Land used or intended to accommodate three (3) or more recreational vehicles, tents, or other individual camping units on a temporary basis.

Cemetery/Memorial Gardens: Land used or intended to be used for the burial of the human or animal dead, including associated buildings such as chapels, mausoleums, and mortuaries if operated in connection with and within the boundaries of such cemetery.

Club: A building or portion thereof or premises owned or operated by a person for a social, literary, political, educational, or recreational purpose primarily for the exclusive use of members and their guests.

Commercial: A use or activity which includes the purchase, sale or exchange of goods or services/including the display and transportation of commodities.

Commercial Parking Lots: Parking lots which are rented, leased or a fee is charged for the use of parking spaces.

Commercial Vehicle: Any motor vehicle with a carrying capacity of over six thousand (6,000) pounds and is used for business or commercial purposes.

Commission: Shall mean the Zoning Commission of Jerusalem Township.

Covenant: A private legal restriction on the use of land, contained in the deed to the property or otherwise formally recorded.

Cul-de-sac: A short street having one (1) end open to traffic and being terminated by a vehicle turn-around.

Convenience Store: A retail store serving a limited local or neighborhood area.

Curb Grade: The elevation of the established curb in front of the building measured at the center of such front. Where no curb grade has been established, the Lucas County Engineer shall establish such curb grade or its equivalent for the purpose of this Resolution.

Day Care Facilities: A place other than the permanent residence, which administers to the needs of children or adults providing social, rehabilitation recreational, or educational activities on a daily basis with no provisions for residential care. Uses include, but are not limited to, adult day care, child day care, rehabilitative care and nursery schools.

Density: A unit of measurement representing the number of dwelling units per acre of land.

- a. **Gross Density** – the number of dwelling units per acre of total land to be developed including right-of-ways.
- b. **Net Density** – the number of dwelling units per acre excluding right-of-ways.

Disabled Vehicle: See **Inoperable Vehicle**.

Dish Antenna (Earth Station): Dish antenna shall mean an accessory structure combination of:

antenna or dish antenna which purpose is to receive communication or other signals from orbiting satellites;

- a. a low noise amplifier (LNA) which is situated at the focal point of the receiving component and whose purpose is to magnify and transfer signals; and
- b. a coaxial cable which purpose is to carry the signals into the interior of the building.

District: A section or sections of Jerusalem Township for which the Zoning Regulations govern the use of buildings and premises, the height of building, the size of yards, the requirements for off-street parking and that the intensity of use are uniform.

Drive-Up: Establishment or facilities where goods or services are provided from windows or in drive through areas to customers in cars or to the cars, and where the cars are temporarily stopped or standing and which commonly does, or could involve a lineup of cars waiting in line for such goods or services. Current examples of drive-up developments include but are not limited to car washes, drive-up windows at banks and fast food restaurants.

Dwelling: Any building or portion thereof which is designed for or used exclusively for residential purposes containing one (1) or more dwelling units.

- a. **Single-family:** A detached building containing one dwelling unit and designed for or occupied by only one (1) family.
- b. **Two-family:** A detached or semi-detached building containing two (2) dwelling units and designed or occupied by two (2) families.
- c. **Multiple:** A building or portion thereof containing three (3) or more dwelling units and designed for or occupied as the home of three (3) or more families living independently of each other.

Dwelling Unit: A group of rooms located within a building and forming a single habitable unit with facilities which are used or intended to be used for living, sleeping, cooking, and eating purposes.

Easement: A grant by the property owner of the use of a part of the property by the public, a corporation or persons for specific purposes.

Excavations: The removal, digging, dredging or relocation of earth, topsoil, sand, gravel, clay, stone, or minerals.

Extraction Industry: The removal of soil, sand, gravel or minerals from land or water for purposes of resale and for use in the commercial operation of a business or the production of a good or service.

Family: "Family" means either a traditional family" or a "functional family" occupying a dwelling unit. A traditional family consists of one or more persons related to each other by birth or marriage. A functional family consists of two or more persons whose relationship is functionally equivalent to a traditional family, but who are not related by blood or marriage. A functional family must have a durable and distinct character with a demonstrable and recognizable bond characteristic of a cohesive unit.

In determining whether a group of unrelated persons is a functional family under the definition set forth above, the following factors, inter alia, may be considered. The presence or absence of any particular factor should be considered in light of any explanation therefor and in light of whether that presence or absence of the permanence and cohesiveness which is indicative of a functional family. The presence or absence of any single factor is not necessarily determinative of whether the unit constitutes a family:

- a. The sharing of social life such that the joint economic, social and cultural life is practiced on a permanent basis.
- b. The presence of minor dependent children regularly residing in the household and enrolled in local schools with one or more members of the household acting in the role of parents.
- c. The household has been living together as a unit for a year or more, whether in the current dwelling unit or other dwelling units.
- d. Whether the individuals use the address of the dwelling unit for the purposes of: voter registration; driver's license; motor vehicle registration; receipt of income by way of federal or other governmental program; legal communications or notices, including health insurance or other programmatic communications; and the payment of taxes.
- e. Evidence that different residents of the dwelling unit are away during the summer and that they have several as opposed to a single summer address is evidence that they are not a functional family.
- f. Common ownership of furniture and appliances.
- g. Full time employment of some members of the household in the general community.
- h. Evidence that one or more individuals are claimed as dependents on the income tax return of individuals not resident in the household is evidence that the household is not a functional family.

Persons occupying a boarding house, hotel, lodging house, group rental house, or fraternity or sorority house, as herein defined do not constitute a functional family.

Living arrangements for persons with a "handicap" and/or a "disability" as those terms are defined by the Fair Housing Amendments Act of 1988 (42 U.S.C. Part 3601 et. Seq.) and the Americans with Disabilities Act of 1990 (42 U.S.C. Part 12101 et. seq.) will be presumed to be a "functional family."

Fence: Any artificially constructed barrier of any material or combination of material erected to enclose or screen areas of land.

Fireworks Definitions:

- a. **"Fireworks"** means any composition of device prepared for the purpose of producing a visible or an audible effect by combustion, deflagration, or detonation, except ordinary matches and except as provided in Section 3743 of the ORC.

- b. **"Manufacturing of Fireworks"** means the making of fireworks from raw materials, none of which in and of themselves constitute a fireworks, or the processing of fireworks.
- c. **"Packaging of Fireworks"** means the assembly, wrapping or placement of fireworks in containers or covering wrapper for sale and or shipment.
- d. **"Processing of Fireworks"** means the making of fireworks from materials all or part of which in and of themselves constitute a fireworks, but does not include the mere packaging or repackaging of fireworks.

Flea Market: A building, structure or site which primary purpose is for the leasing/renting of space, stalls or areas which are used for selling goods or merchandise.

Fowl: Birds that are barnyard, domesticated, or wild, as the duck, goose, turkey, or pheasant. (Rev 12-20-17, Z28-C143)

Frontage: All of the property on one (1) side of a street between two (2) intersecting streets (crossing or terminating), measured at the set back building line – or if the street is dead ended, then all of the property abutting on one side between an intersecting street and the dead-end of the street.

Garage Definitions:

- a. **"Private"** means an accessory building or portion of a main building designed or used for the parking or temporary storage of motor vehicles owned or used by the occupants of the building to which it is accessory; not more than one (1) of such vehicles may be a commercial vehicle not exceeding five (5) ton capacity.
- b. **"Public"** means a building or portion thereof, other than a private or storage garage, designed or used for equipping, servicing, repairing, hiring, selling or storing motor driven or related vehicles.
- c. **"Storage"** means a building or portion thereof designed or used exclusively for storage of motor driven or related vehicles, and at which motor fuels and oils are not sold, and such vehicles are not equipped, serviced, repaired, hired or sold.

Garage Sale: The sale of miscellaneous, used household goods, clothing, tools etc., usually displayed and sold outdoors on residential property, but not auctioned as in Auction/Market.

Greenhouse: A building or structure enclosed with glass or other glazing used for the cultivation and production of plants.

Hazardous Waste: Any waste or combination of waste in solid, liquid, semisolid or contained gaseous form which falls within the definition of hazardous waste under 3734.01(j) ORC.

Health Care Clinics: A health care facility which provides for diagnosis and treatment services on an emergency or outpatient basis with no provisions for residential care.

Home Occupation: An occupation carried on exclusively by the occupant(s) of a dwelling as a secondary use and does not involve the selling of a commodity other than that produced upon the premises.

Hospital: A health care facility which provides for diagnostic, medical, surgical or psychiatric treatment and care. It may include but not limited to related facilities for educational and training facilities for health professionals.

Hotel: A building in which lodging, or boarding and lodging, are provided and offered to the public for compensation and in which ingress and egress to and from all rooms is made through an inside lobby or office normally supervised by a person in charge at all hours. As such, it is open to the public as distinguished from a boarding house, a lodging house, or an apartment which are herein defined.

House Trailer: See **Manufacture Home.**

Industrialized Unit: "Industrialized Unit" means a building unit or assembly of closed construction fabricated in an off-site facility, that is substantially self-sufficient as a unit or as part of a greater structure, and that requires transportation to the site of intended use. "Industrialized unit" includes units installed on the site as independent units, as part of a group of units, or incorporated with standard construction methods to form a completed structural entity. "Industrialized unit" does not include a manufactured or mobile homes as defined in this Zoning Resolution.

Inoperable Vehicle: Inoperable vehicle means any motor vehicles which meets one of the following requirements:

- a. It does not display a valid license plate and is in either wrecked, partially wrecked, dismantled, partially dismantled, or discarded condition, or is incapable of being driven; or
- b. It is wrecked, partially wrecked, dismantled, partially dismantled, discarded or is incapable of being driven and has remained in such condition for a continuous period of fourteen (14) days.

Inoperable Watercraft: Inoperable watercraft means any watercraft which meets one of the following requirements:

- a. It does not display a valid state registration sticker and is in either wrecked, partially wrecked, dismantled, partially dismantled, or is in a discarded condition or is incapable of being piloted.
- b. It is wrecked, partially wrecked, dismantled, partially dismantled, discarded or is incapable of being piloted and has remained in such condition for a continuous period of fourteen (14) days.

Institution: Buildings or land occupied by a nonprofit corporation or a nonprofit establishment for public use.

Institutional Health Care Facilities: A public or nonprofit institution which provides for residential health care and maintenance for mental health or developmentally disabled persons.

Junk Yard: An open area where waste, scrap metal, paper, rags, or similar materials are brought, sold, exchanged, stored, packed, or handled, including building wrecking yards, but excluding uses taking place entirely within an enclosed building.

Kennels: Any lot or premises on which four (4) or more dogs, more than four (4) months of age, are kept for boarding purposes or medical care.

Land Use Plan: Shall mean the "Jerusalem Township Land Use Plan" as adopted and amended by the Lucas County Planning Commission and Lucas County Commissioners in accordance with the Ohio Revised Code.

Livestock: "Livestock" means cattle, sheep, goats, and other animals of the family bovidae, swine and other animals of the family suidae, and horses, mules, burros, asses, and other animals of the family equidae.

Loading Berth or Space: A space within the main building or on the same lot, providing for the standing, loading or unloading of trucks, having a minimum dimension of twelve (12') by fifty (50') feet and a vertical clearance of at least fifteen (15') feet.

Lodging House: See **Boarding House**.

Lot Definitions:

Lot: A parcel of land occupied or intended for occupancy by a use permitted in this Resolution, including one main building together with its accessory buildings, the parking spaces, yard, and lot area as are required by this Resolution, and having its principal frontage upon a public street or place.

- a. **Lot Area** – The total horizontal area within the boundaries of a lot exclusive of all rights-of-way of any access easement, alley, public or private street.
- b. **Lot, Corner** – a lot abutting upon two (2) or more streets at their intersection.
- c. **Lot Coverage** – the ratio of enclosed ground floor area of all buildings on a lot to the horizontally projected area of the lot, expressed as a percentage.
- d. **Lot Depth** – the horizontal distance between the front and rear lot lines, measured along the median between the two (2) side lot lines.
- e. **Lot Frontage** – the horizontal distance of the boundary line of a lot abutting a street or road right-of-way. On corner or through lots, the street or building address shall be considered frontage.
- f. **Lot, Double Frontage** – a lot having a frontage on two (2) non-intersecting streets as distinguished from a corner lot.
- g. **Lot, Interior** – a lot other than a corner lot.

Lot of Record – a lot which is part of a subdivision, the map of which has been recorded in the office of the Lucas County Recorder; or a parcel of land described by metes and bounds, the description of which has been recorded in the office of the Lucas County Recorder.

- h. **Lot, Width** – the horizontal distance between the side lot lines, measured at right angles to the lot depth at the legally established building setback line.

Major Street: A dedicated street within Lucas County which has been classified as a dual highway, dominant major street, a major street, a secondary major street, or a main county road on the official Toledo-Lucas County Major Street Plan.

Major Street Plan: Toledo-Lucas County Major Street Plan which designates roadways as expressways, principal arterial, minor streets, major collectors or local collectors.

Manufactured Home: "Manufactured Home" means a building unit or assembly of closed construction fabricated in an off-site facility, designed for assembly at the building site, bearing certification that it is built in conformance with the Federal Manufactured Housing Construction and Safety Standards established by the Secretary of the U.S. Department of Housing and Urban Development pursuant to the "Manufactured Housing and Construction Safety Act of 1974".

Manufactured Home Park: "Manufactured Home Park" Any lot, parcel or tract of land designed exclusively for the occupancy by manufactured homes or mobile homes, used for human habitation, are parked, either free of charge or for revenue purposes, which include any roadway, building, structure, vehicle or enclosure used or intended for use as part of the facilities of such Manufactured Home Park.

Manufacturing: A process which combines raw materials or components into a product or which changes their physical or chemical characteristics.

- a. **General Manufacturing** – manufacturing, which by its nature and function may require large parcels, effective separation from residential and most commercial areas, confinement within enclosed buildings and screened enclosures having an opaqueness of seventy-five (75%) percent or greater, where outside storage of materials are necessary. General Manufacturing shall include but not be limited to processing of vegetables and fruit, dairy and bakery products, soft drinks and confections, textiles, glass, wood and plastic production, and fabrication, pharmaceutical, metal fabrication, machining, tool and die, hardware and appliance production.

Heavy Manufacturing – manufacturing which requires large acreage parcels for isolation and separation from residential and commercial development, special consideration because of the potential spill over effect on surrounding areas and the use of buildings and open areas of the parcel for processing production and storage of materials. Heavy manufacturing shall include, but not be limited to, smelting and primary metal processing, mineral extraction, metal salvage and fabrication, motor vehicles and related products, manufactured housing, household appliances, manufacturing, chemical and gas manufacturing, refining, manufacturing and/or processing of animals, or animal parts for food, fertilizer or other purposes including the tanning and production of leather goods and furs.

Restricted Manufacturing – any industrial use which is conducted entirely within enclosed substantially constructed buildings; involving the use of only light machinery and equipment; does not use the open area about the buildings for the storage of materials or equipment other than for the unloading or loading operations at the rear or within an enclosure which abuts a building. Restricted Manufacturing shall include the manufacture of drugs, jewelry, musical instruments, sporting goods; the processing and assembly of small glass products; small household appliances, small electronic products, scientific instruments, and parts for the production of finished equipment; office, computing and accounting machines; research and laboratory testing; printing, publishing and engraving plants; and other similar products and operations.

Marina: A facility which contains a minimum of six (6) boating berths or slips and provides for dockage, storage, and/or mooring of watercraft; associated service, refueling and repair of watercraft: and/or accessory uses such as restaurants, places which provide food and beverages, boating supplies, bait and fish cleaning, but not including drive-thru's. A yacht club shall be considered a marina.

Marine Sales and Service: The sale and service of water craft and marine equipment.

Massage Parlor: An establishment or place primarily in the business of providing massage services operated by anyone not a duly licensed medical doctor, osteopath, chiropractor, nurse, physical therapist treating patients recommended by a licensed physician under a duly licensed physician's direction, or person practicing the art of massage on the face or hands in a duly licensed beauty parlor or barber shop.

Medical Marijuana Facility: Any entity that has been issued a certificate or license by the State of Ohio to operate as a cultivator, dispensary, processor or testing facility of medical marijuana. The following are Medical Marijuana Facility use types:

- a. **Cultivator:** An entity that has been issued a certificate of operation by the State of Ohio to grow, harvest, package, and transport medical marijuana.
- b. **Dispensary:** An entity licensed by the State of Ohio to sell medical marijuana products to qualifying patients and caregivers.
- c. **Processor:** An entity that has been issued a certificate of operation by the State of Ohio to manufacture medical marijuana products.
- d. **Testing Laboratory:** An independent laboratory that has been issued a certificate of operation by the State of Ohio to have custody and use of controlled substances for scientific and medical purposes and for purposes of instruction, research, or analysis.

(Rev 12-20-17, Z28-C142)

Mobile Home: "Mobile Home" means a factory built building unit which contains a mobile component as an integral part of the unit, designed for transportation, after fabrication, to the site at which it is to be occupied as a building unit complete and ready for occupancy, except for minor and incidental unpacking and assembly operations, location on jacks or other foundations and connection essential public utilities. "Mobile Home" does not qualify as a "Manufactured Home" or as an "Industrialized Unit" as defined in this Zoning Resolution.

Mobile Home Park: See Manufacture Home Park.

Modular Home: A factory built dwelling unit designed for assembly at the building site, bearing certification of compliance with the Ohio Building Code and meets the definition of Industrialized Unit [ORC. 3781.10(j)].

Motel: A building or group of buildings containing sleeping accommodations primarily intended for use of transients traveling by automobile.

Motor Vehicle: Any self-propelled vehicle, except vehicles not designed for or employed in general highway transportation.

Motor Vehicle Body Shop: Means any building, structure, or land used primarily for major motor repair, body or fender work, or painting of motor vehicles.

Motor Vehicle Service Station: Any premises used for supplying gasoline and oil, at retail direct to the customer, including accessories, parts and minor services or repair for motor vehicles, but not including body or fender work, painting or major motor repairs. When the aforementioned service is incidental to the conduct of a public garage, the use shall be classified as a public garage.

Motor Vehicle Sales and Rental: The sale or rental of new and used motor vehicles, motorcycles, recreational vehicles, trailers, or travel trailers, to be displayed and sold on the premises and accessory services.

Motor Vehicle/Watercraft Salvage: the dismantling, wrecking and/or salvage of used motor vehicles/watercraft or trailers, or the storage, sale, or dumping; of dismantled, partially dismantled, obsolete or wrecked vehicles/watercraft or their parts.

Motor Vehicle/Watercraft Salvage Yard: Any place where two (2) or more motor vehicles/watercraft not in running condition, or parts thereof are stored in the open, in a fenced areas, or in a partially enclosed building, and are not being restored to operation, or any land used for wrecking, storing and/or salvage of such motor vehicles/watercraft or farm machinery, or parts thereof, stored in the open and not being restored to operating conditions.

Non-conforming Uses: Any building or land lawfully occupied by a use at the effective date of this Resolution, or amendment thereof, which does not conform after the passage of this Resolution, or amendment thereof, with the use requirements of the district in which it is situated.

Nursery School: A school designed to provide daytime care for instruction for two (2) or more children from two (2) to five (5) years of age, inclusive, and operated on a regular basis.

Nursing Home: A home for the aged or chronically ill persons in which sixteen (16) or more persons not of the immediate family are received, kept, and provided with food, shelter and care, for compensation; but not including hospitals, clinics, or similar institutions devoted primarily to the diagnosis and treatment of the sick.

ORC: Means the Ohio Revised Code.

Overlay District: An additional secondary zoning classification which establishes additional regulations on the use of land, buildings or structures.

Parking Lot: Any off-street area or structure which meets one of the following conditions:

1. Contains one (1) or more parking, vehicular storage, loading or stacking space for commercial, institutional, recreational or industrial use, whether free or for compensation; or
2. Contains five (5) or more parking spaces for any residential use.

Parking Space: An area enclosed in the main or accessory building, or unenclosed, reserved for the temporary storage of one (1) automobile and connected to a street or alley from a driveway which affords satisfactory ingress and egress for automobiles.

Performance Bond or Surety Bond: An agreement by a subdivider or developer with the township for the amount of the estimated construction cost guaranteeing the completion of physical improvements according to plans and specifications within the time prescribed by the subdivider's agreement.

Permanent Foundation: A permanent masonry, concrete, or locally approved footing or foundation to which a manufactured or mobile home may be affixed.

Permanently Sited Manufactured Home: A manufactured home that meets all of the following criteria:

- a. The structure is affixed to a permanent foundation and is connected to appropriate facilities;
- b. The structure, excluding any addition, has a width of at least twenty-two (22') feet at one point, a length of at least twenty-two (22') feet at one point, and a total living area of at least one thousand two hundred (1,200) square feet, excluding garages, porches, or attachments;
- c. The structure has a minimum 3:12 residential roof pitch, conventional residential siding, and a six-inch minimum eave overhang, including appropriate guttering;
- d. The structure was manufactured after January 1, 1995;
- e. The structure is not located in a manufactured home park, as defined in this Resolution.

Personal Services: Any enterprise conducted for gain which primarily offers services to the general public such as shoe repair, watch repairing, barber shop, beauty parlors and similar activities.

Petting Zoo: An area or building which contains animals for viewing and/or interaction by the public.

Place: A private thoroughfare other than a street or alley permanently reserved as a lot on a recorded plat as the principal means of access to abutting property approved under applicable Subdivision Regulations by the Toledo-Lucas County Plan Commissions in accordance with ORC 711 and 713.

Planned Unit Development: An area of land in which a variety of housing types and subordinate commercial and industrial facilities are accommodated in a preplanned environment under more flexible

standards, such as lot sizes and setbacks, than those restrictions that would normally apply under these regulations.

Plat: A map or drawing of a tract or parcel of land.

Plot Plat: See **Site Plan**.

Pond: A body of water covering not less than one-fourth acre in total area, and which is being used for any one (1) of the following purposes: to provide water for livestock, fish and wildlife, recreation, fire control, crop and orchard spraying, and related uses.

Private Garage: See **Garage**.

Professional Services: The use of offices and related spaces for such services which are provided by doctors, dentists, lawyers, architects and engineers.

Public Garage: See **Garage**.

Public Service Facilities: Structures, buildings, and/or transmission, distribution, or collection systems, which are used to provide and maintain public utilities. Uses include, but not limited to, railroad, electric, gas, water and sewer, and telephone systems and other uses which meet the definition of public utility under ORC 4905.03.

Public Uses: Uses which provide or maintain public services. These include, but not limited to, government buildings, schools, public parks, highway maintenance, and storage facilities.

Recreational Facilities: Buildings, structures, lands or water areas used for social, leisure and recreational activities. These include, but not limited to, golf courses, clubs, sports field, indoor/outdoor courts, community/public – swimming pools, amusement centers, banquet halls, tourist resorts, carnivals or parks.

Recreational Vehicle: Any vehicular portable structure designed and constructed to be used as a temporary dwelling for travel, recreational or vacation purposes. This includes, but is not limited to, motor homes, travel trailers, tent campers and truck campers.

Recreational Vehicle Park: See **Campground**.

Residential Floor Area: The interior floor area of a dwelling including stairways, halls, and closets but not including basement, porches, garages, breezeways or carports.

Retail Sales: Businesses involved in the sale, lease or rent of new or used products to the general public. Excludes Animal Services, Construction Sales and Service, Gasoline and Fuel Sales, and Vehicle Sales and Service. Typical uses include department stores, drug stores, apparel stores, furniture stores, and grocery stores and convenience stores.

Rooming House: See **Boarding House**.

Screen Fence: A fence, not less than three (3) feet in height, which by its construction is opaque and screens from view.

Screen Planting: A continuous planting of evergreen plant material, providing a visual barrier and maintained at a height of between three (3) and seven (7) feet.

Self Service Storage Facility: Any real property designed and used for the purpose of renting or leasing individual storage spaces for the storage of personal property.

Semi-Public Uses: Services and facilities which are provided to the public that are privately owned and controlled. These include, but are not limited to, churches, parochial schools, hospitals, and other educational, religious or philanthropic organizations and telecommunication facilities.

Setback Line: A line established by zoning, platting, or other legal means on a lot, that is a specified distance from and parallel to the lot line, to restrict the encroachment of buildings on the lot line.

Sexually oriented business: Means an adult bookstore, adult video store, adult movie house, adult amusement or entertainment, adult cabaret, or massage establishment.

- a. **Adult Book Store:** An establishment which has a substantial portion of its inventory in books, magazines or other periodicals, from which minors are excluded by virtue of age.
- b. **Adult Video Store:** An establishment which has a substantial portion of its stock in movies, for sale or for rent, from which minors are excluded by virtue of age.
- c. **Adult Movie Store:** An establishment displaying; movies that are rated X, XX or XXX which is customarily not open to the general public by excluding minors by virtue of age.
- d. **Adult Amusement or Entertainment:** An establishment customarily engaged in the presentation of nude and seminude exhibitions and performances for commercial or pecuniary gain which excluded minors by virtue of age. This definition does not apply to the exhibition, presentation, showing or performance of any play, ballet, drama, tableau or production in any theater, concert hall, museum of fine arts, school, institution of higher learning or similar establishment which is primarily devoted to such exhibitions, presentations, show information, art of drama as differentiated from commercial or business advertising, promotion, selling or servicing products or services or otherwise advancing the economic welfare of a commercial or business enterprise such as a hotel, motel, bar, nightclub, restaurant, tavern or dance hall.
- e. **Adult Cabaret:** Means a nightclub, bar, restaurant, or similar establishment in which persons appear in a state of nudity in the performance of their duties.
- f. **Massage Establishment:** Means any place of business where a person offers massages either in exchange for something of value, or in connection with providing another legitimate service, and which is operated by anyone other than persons who are certified to practice under Ohio Revised code Section 4731.15 and 4731.16 or who are engaged in the practice of providing therapeutic massage as a licensed physician, chiropractor, podiatrist, nurse or other health professional licensed, certified or registered to practice in Ohio.

g. **Nudity:** Means the showing of either of the following:

1. The human male or female genitals, pubic area, or buttocks with less than a fully opaque covering;
2. The female breast with less than a fully opaque covering on any part of the nipple.

Shipping Container: An article of transport equipment that is of a permanent character and accordingly strong enough to be suitable for repeated use; it is designed to transport a number of receptacles, packages, unit loads, and over packs together from the packing point to its final destination by road, rail, inland waterway and/or sea without intermediate separate handling of each package. (Rev 12-20-17, Z28-C143)

Shopping Center: A group of retail businesses and services on a single site with common parking facilities and containing building(s) floor area of one hundred thousand (100,000) square feet or greater.

Sign: A name, identification, description, display or illustration which is affixed to, painted or represented, directly or indirectly upon a building, structure, parcel, or lot and which directs attention to an object, product place, activity, person, institution, or organization or business. A sign shall not include official court of government notices nor shall it include the flag, emblem or insignia or nation, political unit, school, or religion. Further, it shall not include the display of merchandise in a window, but shall include temporary or permanent signs attached to the outside or inside of a window. It shall also include "Banners", "Pennants", "Commercial Signs", "Bulletin Boards", "Poster Billboards", and "Electric Signs".

Site Plan: A scaled drawing of a proposed project showing, among others, the location of property lines, building locations, drives, walkways, parking areas, fencing and screening, setbacks, and signs as required by this Resolution.

Sludge: Any by-product of sewage treatment or industrial waste treatment.

Solid Waste: Unwanted residual solid or semi-solid material which results from industrial, commercial or municipal operations. These include, but are not limited to garbage, combustible or non-combustible street dirt or debris and falls within the definition of solid waste under ORC 3734.01(e).

Special Use: A use other than a use by right, subject to review, approval/disapproval by the Board of Township Trustees.

Storage Garage: See **Garage**.

Story: That portion of a building included between the surface of any floor and the surface of the next floor above it, or, if there be no floor above it, then the space between such floor and ceiling next above it.

Story, Half: A story under a gable, hip or gambrel roof, the wall plates of which on at least two (2) opposite exterior walls are not more than two (2) feet above the floor of such story.

Street: A public thoroughfare which affords the principal means of access to abutting property. For the purpose of this Resolution, the word street shall include the words "road" and "highway".

Structure: Anything constructed or erected, the use of which requires more or less permanent location on the ground or attached to something having a permanent location on the ground, including but without

limiting the generality of the foregoing, advertising signs, billboards, back stops for tennis courts, and pergolas.

Structural Alterations: Any change which would tend to prolong the life of a supporting member of a structure such as bearing walls, columns, beams or girders.

Swimming Pool: An enclosure, temporary or permanent, above or below ground, containing water to be used for bathing, wading or swimming, which shall be able to contain twenty-four (24") inches minimum depth of water and exceeds twelve (12') feet in diameter or length whichever applies to the appropriate shape.

Surface Mining: All or any part of a process followed in the production of minerals from the earth or from the surface of the land by surface excavation methods, such as open pit mining, dredging, mineral extraction, or quarrying.

Telecommunication Tower: Any structure with radio frequency transmission or reception equipment attached that is free standing or is to be connected to a building or other structure. A telecommunication tower shall meet all of the following conditions:

- a. It is constructed on or after October 31, 1996;
- b. It is owned or principally used by a public utility engaged in the provision of telecommunication service;
- c. It is a freestanding structure or is attached to another building or structure and is higher than the maximum allowable height permitted in the zoning district in which it is located.

Tourist Camp: Same as **Campground**.

Tourist Court: Same as **Motel**.

Tourist Home/Tourist Resort: A building or buildings, other than a hotel or motel, used for temporary lodging, in which either board or rooming is provided and offered to the public for compensation.

Trailer: A vehicle on wheels, skids, or rollers without motive power and designed for temporary human habitation, carrying persons or property.

Trailer Camp: Same as **Campground**.

Truck Terminal: Land and buildings used as a relay station for the transfer of a load from one (1) vehicle to one party to another. The terminal facility may include storage areas for trucks and buildings or areas for the repair of trucks associated with the terminal.

Use: The purpose for which land or building is arranged, designed or intended, or for which either land or a building is or may be occupied or maintained.

Variance: A variance is a modification of the strict terms of the relevant regulations where such modification will not be contrary to the public interest and where owing to conditions peculiar to the

property and not the result of the action of the applicant, a literal enforcement of the regulations would result in unnecessary and undue hardship.

Warehouse: A building or structure used for the storage of goods, materials or equipment.

Waste: See **Hazardous Waste, Sludge, Solid Waste.**

Watercraft: Means a broad term for all waterborne vehicles, and it is used without reference to size, may or may not have living accommodations, may be powered by an internal combustion engine or other motor, sail, oars or paddle.

Yard:

- a. **"Yard"** means an open space or grade between a building and the adjoining lot lines and unoccupied and unobstructed by any portion of a structure from the ground upward, except as otherwise provided herein. In measuring a yard for the purpose of determining the width of a side yard, the depth of a front yard or the depth of the rear yard, the minimum horizontal distance between the lot line and the main building shall be used.
- b. **"Yard, Front"** means a yard extending across the front of a lot between the side lot lines, and being the minimum horizontal distance between the street and the main building or any projections thereof other than the permitted projections of unenclosed porches.
- c. **"Yard, Rear"** means a yard extending across the rear of a lot between the side lot lines and being the required minimum horizontal distance between the rear lot line and the rear of the main building or any projections thereof other than the permitted projections or uncovered steps, unenclosed balconies, or unenclosed porches. On all lots, the rear yard shall be at the opposite end of the lot from the front yard.
- d. **"Yard, Side"** means a yard between the main building and the side line of the lot, and extending from the required front yard to the required rear yard, and being the minimum horizontal distance between a side lot line and the side of the main buildings or any permitted projections thereof.

Yard/Lawn/Barn Sale: See **Garage Sale.**

Zoning Inspector: The agent, appointed by the Township Trustees, who is responsible for the administration of the Township Zoning Regulations and required inspections for zoning compliance.

Zoning Certificate (Permit): The document issued by the zoning inspector authorizing the use of land or buildings.

Zoning District Map: Map or maps of the township and amendments delineating zoning districts.